

CS200 Curve Sensor Control Unit

1-8012-US

For wheel-flange lubrication systems

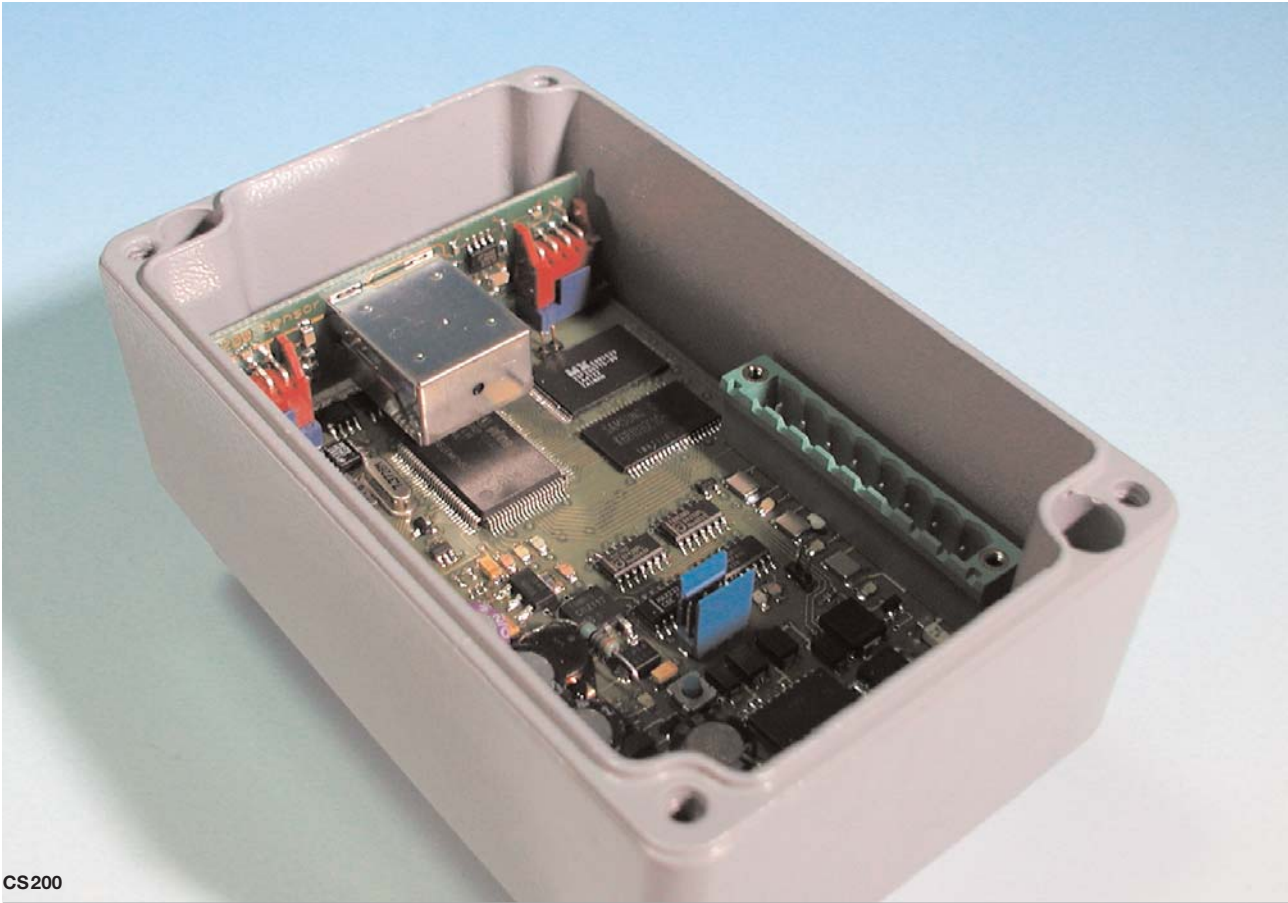

CS200

- **Modes of Operation**

- Curve lubrication
- Time-controlled lubrication
- Distance-controlled lubrication
- Curve-/time-controlled lubrication
- Randomly controlled lubrication after power-up
- Curve sensor for external control unit

- **Powerful valve outputs**

- **Adjustable sensitivity**
depending on practical needs

Practical examples

- Stand-alone wheel-flange control unit
- Curve sensor to supplement wheel-flange control units
- Curve sensor for lubrication control by railway SPC



www.vogelag.com

VOGEL®
Central
Lubrication

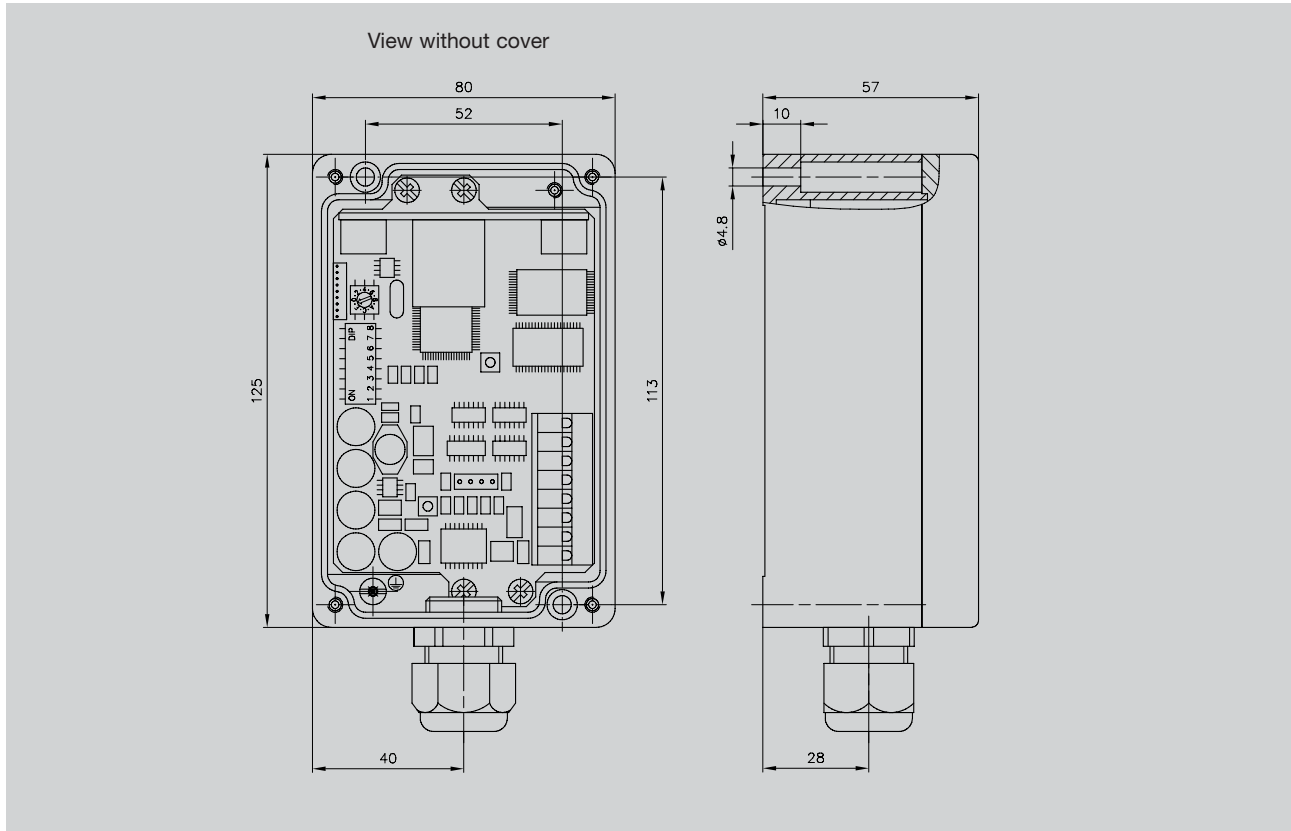

Technical Data

Order No. **CS 200**

Housing
 Material aluminum
 Dimensions [mm] 125x80x57 (LxWxH)
 Type of enclosure to
 EN 60 529/10.91 IP 65
 Weight 570 g

Ambient temperature
 Class T1
 Operation -30 °C to +65 °C
 Storage and transport -40 °C to +85 °C

Cable gland 1x M20x1.5

Terminals spring-loaded terminals for
 core diameters of 0.2 - 2.5 mm²

Operating voltage 24 V DC
 Closed-circuit power consumption I_N : 50 mA
 Operating voltage tolerance -50%, +30%
 Polarity reversal protection yes

Clock-pulse spaces [s] 1.5; 3; 4.5; 5.5

Spray time [s] 1.5

Curve sensor
 Detection threshold adjustable in 15 stages from 0.3 %/s to 1.3 %/s

Time-controlled operation
 Spray period [s] 10 to 244

Distance-controlled operation
 Input pulses 500 to 123,000 in 15 stages

Inputs
FG – enable
VR – direction of travel
P – distance pulses: optically separate input

Input impedance
 Inputs **FG, VR** $\approx 1.7 \text{ k}\Omega$
 Input **P** $\approx 4.4 \text{ k}\Omega$

Input voltage
 Inputs **FG, VR** min. 12 V
 Input **P** min. 1.8 V

Input frequency
 Input **P** max. 2 kHz

Outputs
 Short-circuit proof
 Rated output current 1 A per output

Standards
 EN 50 153, EN 50 155, EN 50 121-3-2
 (EMC for railway equipment);
 Electromagnetic Compatibility EMC 89/336/EEC:
 EN 50 081-1, EN 50 082-2

Subject to change without notice! 0000 05/2002



WILLY VOGEL AKTIENGESELLSCHAFT

Willy Vogel AG
 Motzener Strasse 35/37
 12277 Berlin, Germany
 P.O. Box 97 04 44 · 12704 Berlin

Phone (++49) 30-7 20 02-0
 Fax (++49) 30-7 20 02-111
 E-mail info@vogel-berlin.de
 Internet www.vogelag.com