

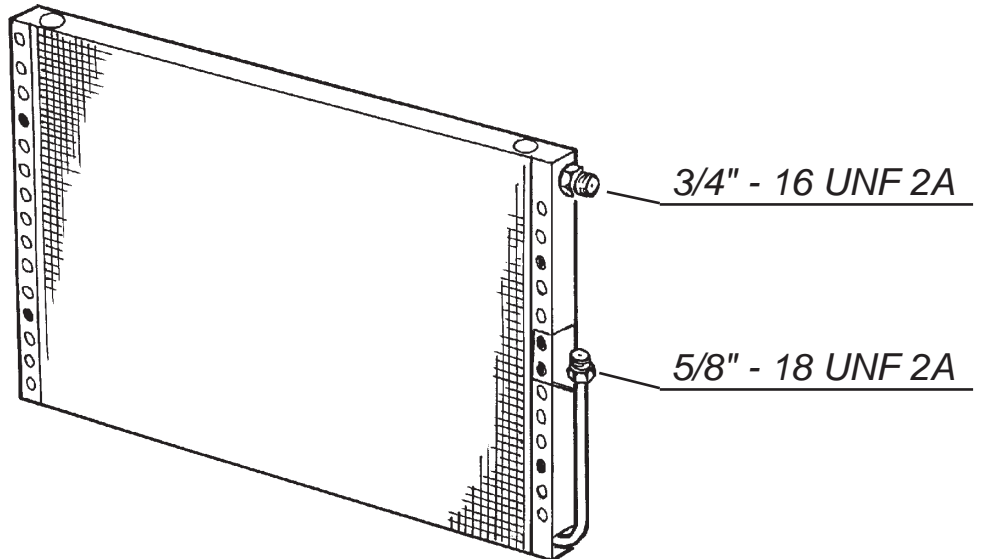

CONDENSADORES STANDARD

*STANDARD
CONDENSERS*

Condensatori a flusso parallelo SANDEN MFC standard
Standard parallel flow condensers SANDEN MFC



CARATTERISTICHE TERMICHE
CONDENSER COIL PERFORMANCE

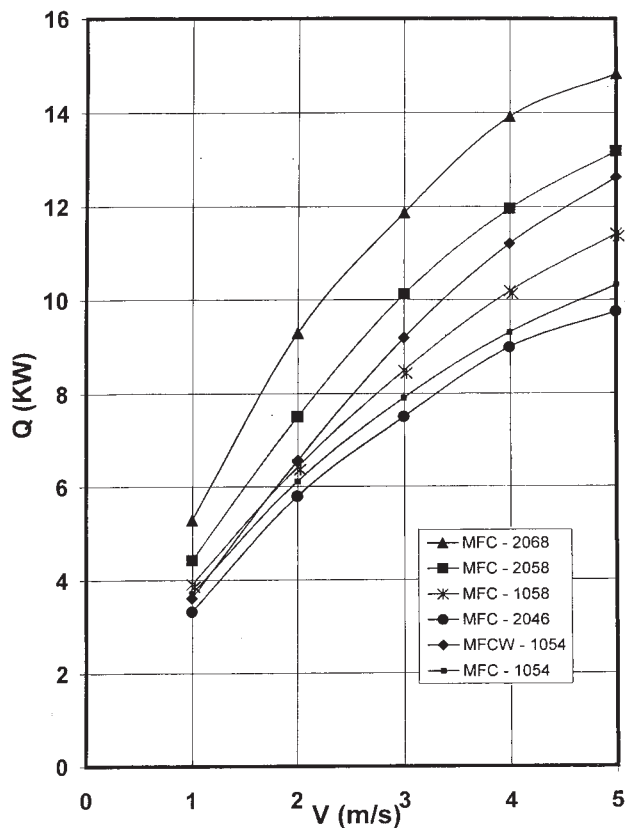

SANDEN MFC-1054AE

(mm. 540 x 310 x 16)

C.88.12.509.A

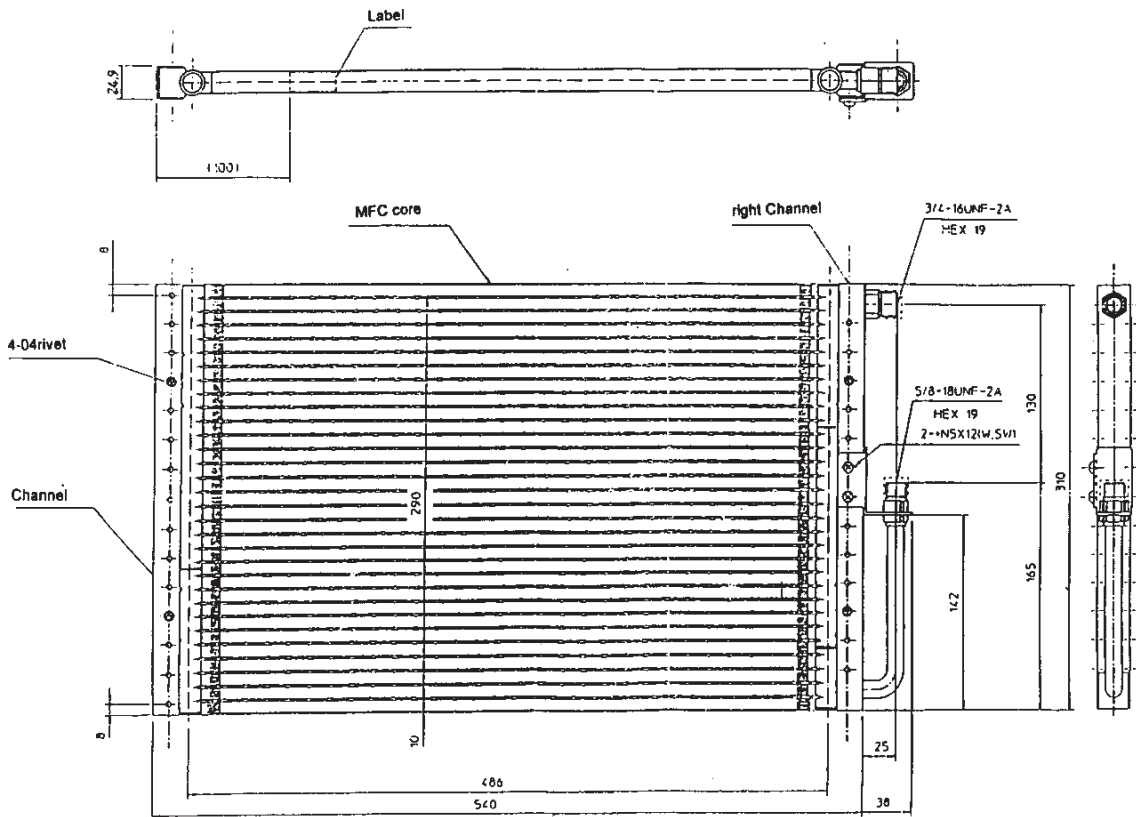

SANDEN MFCW-1054AE

(mm. 540 x 310 x 25)

C.88.12.509.A.MFCW

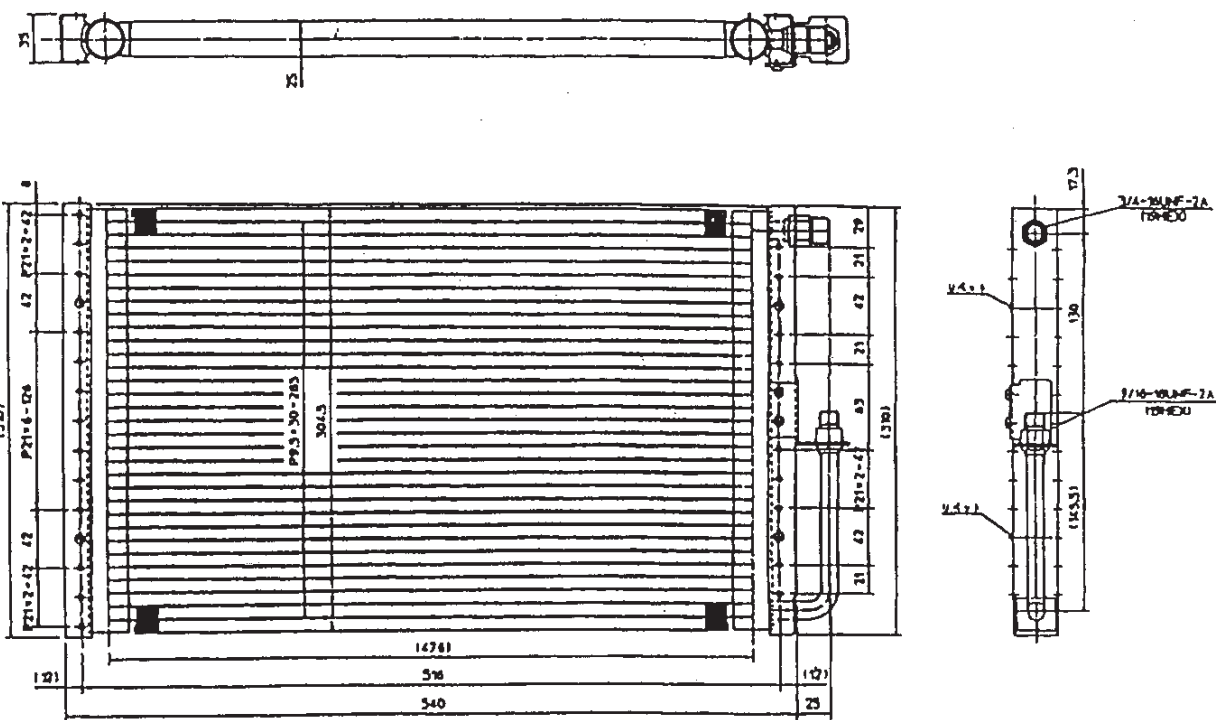

SANDEN MFC-1058AE

(mm. 580 x 310 x 16)

C.88.12.508.A

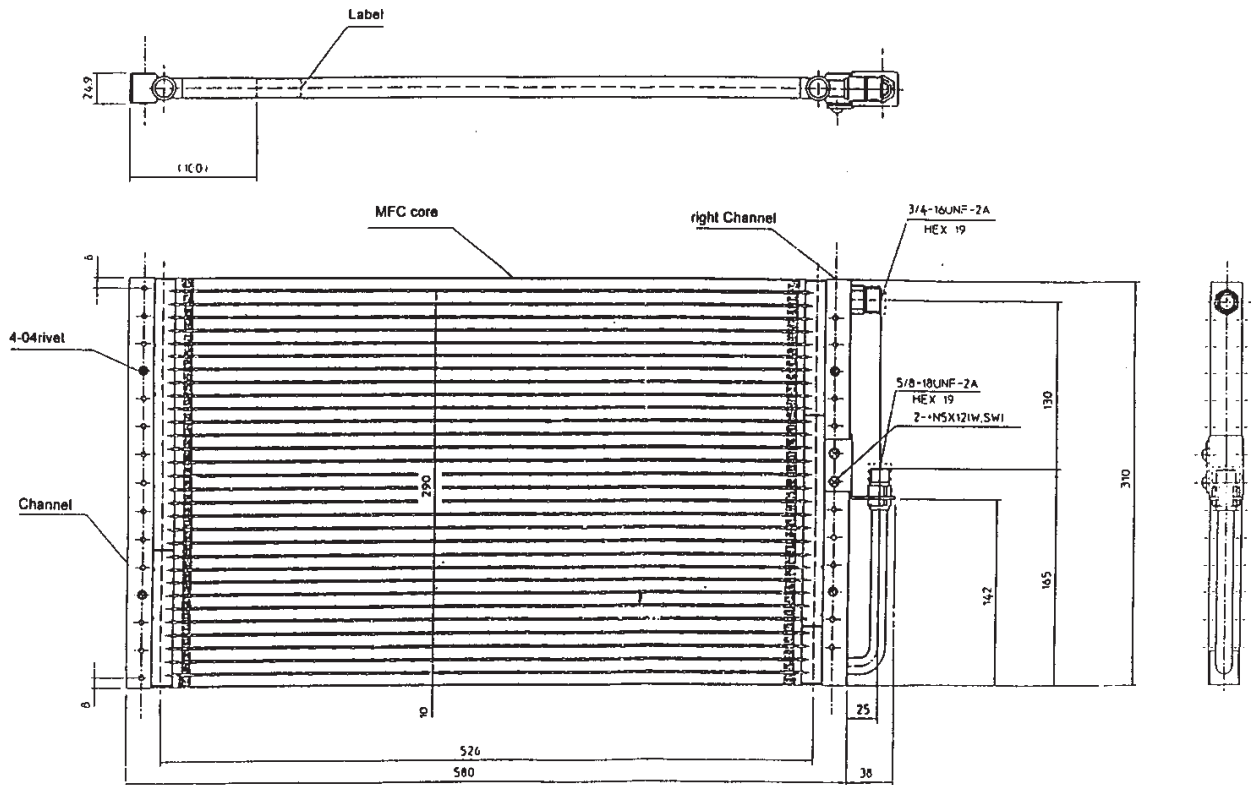

SANDEN MFC-2046AE

(mm. 460 x 360 x 16)

C.88.12.507.A

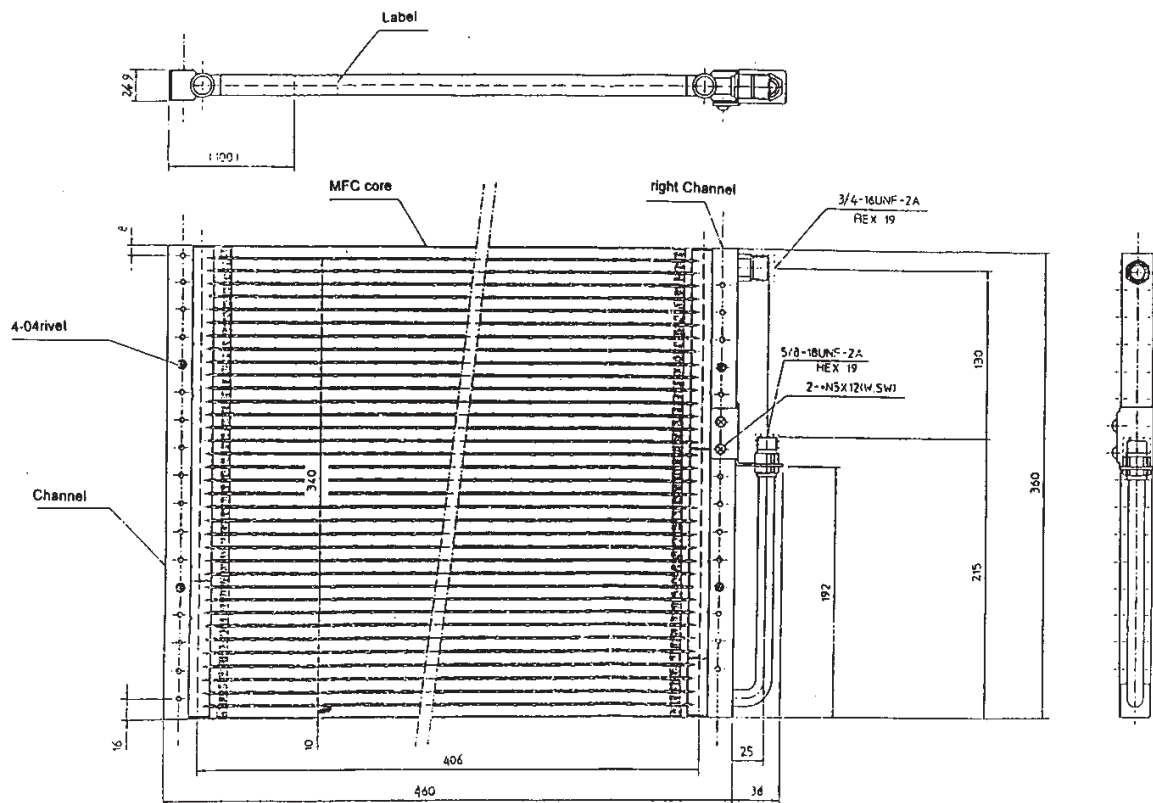

SANDEN MFC-2058AE

(mm. 580 x 360 x 16)

C.88.12.520.A

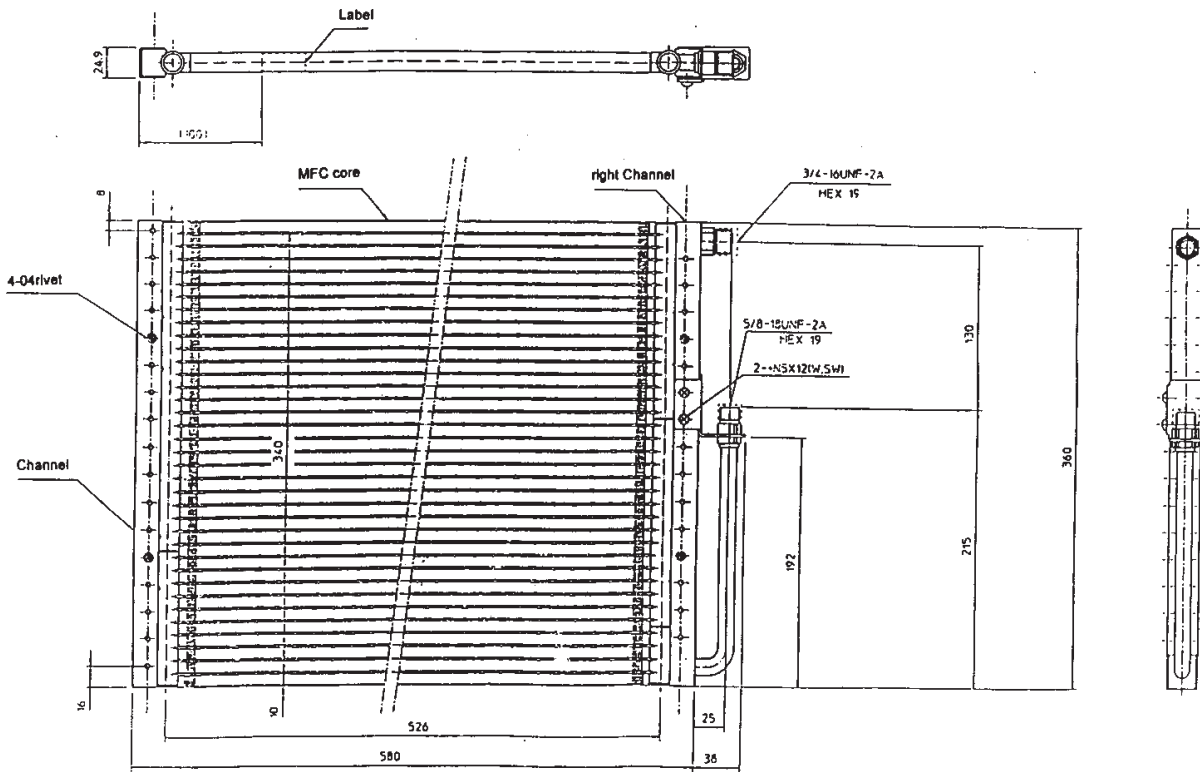

SANDEN MFC-2068AE

(mm. 680 x 360 x 16)

C.88.12.522.A

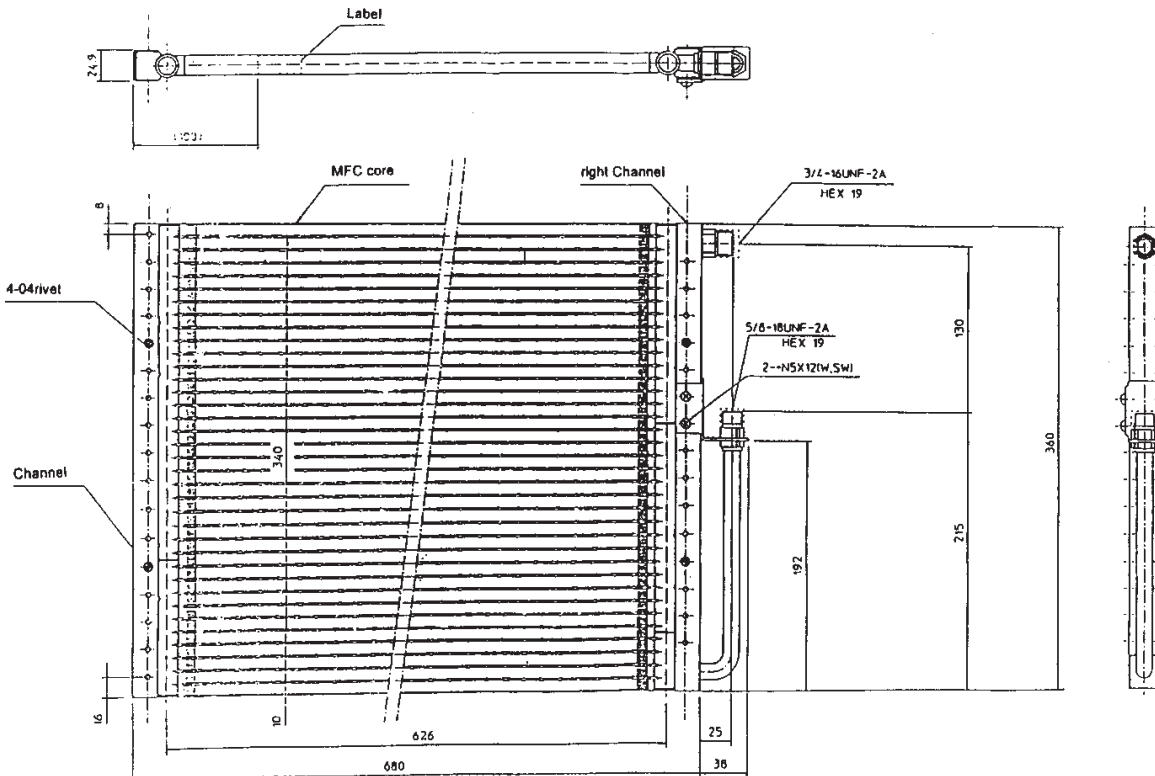

Grand Ocean - Dual flow

(mm. 584 x 305 x 22)

C.88.12.576.A

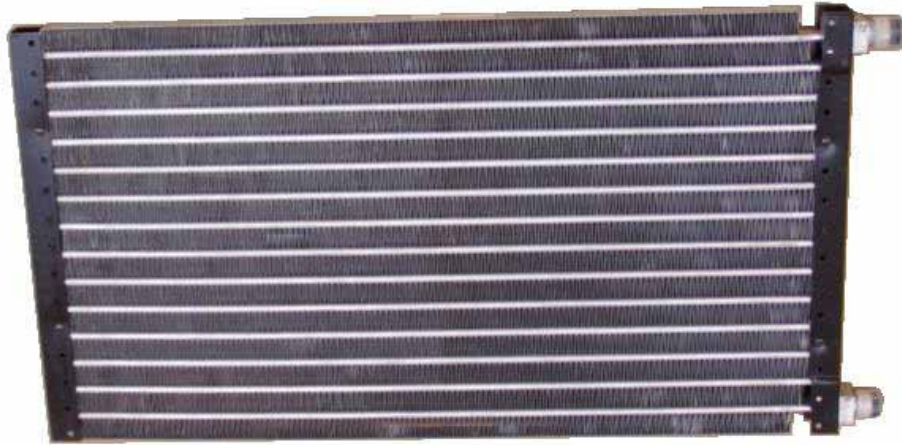

Grand Ocean - Dual flow

(mm. 584 x 356 x 22)

C.88.12.582.A

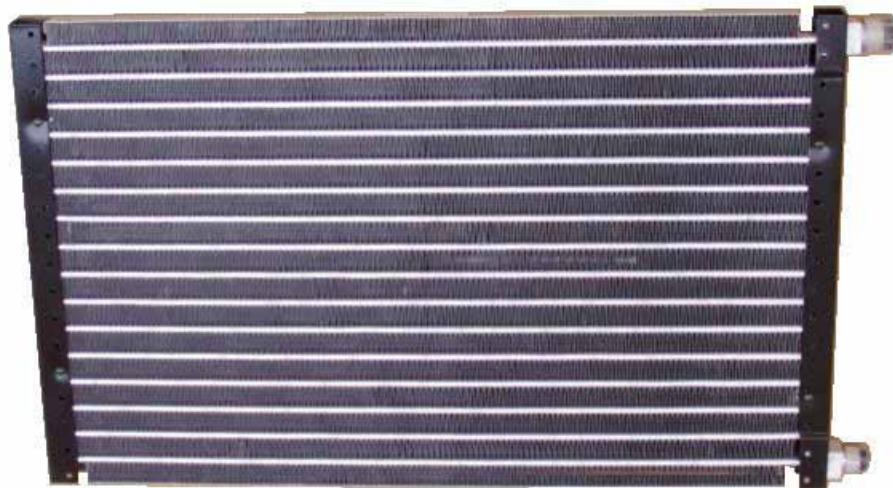

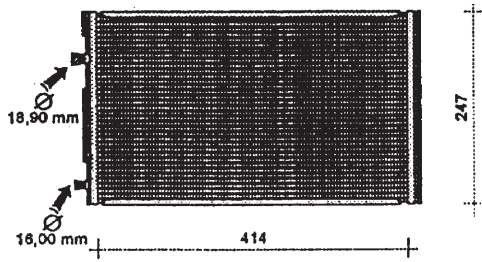

C.88.12.592.A 022296OR

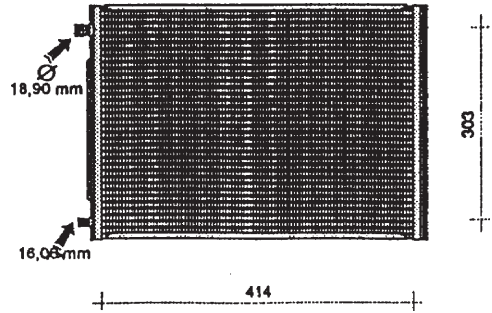

C.88.12.593.A 022297OR

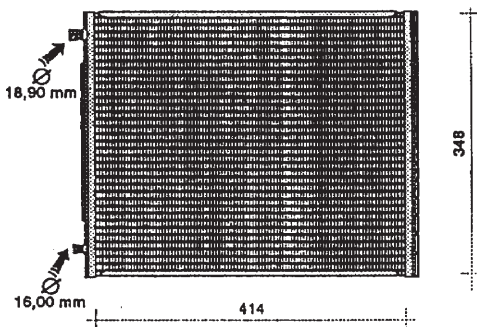

C.88.12.561.A 022298OR

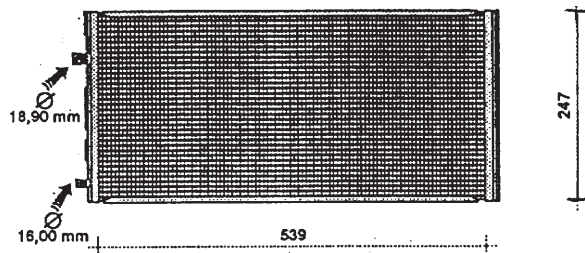

C.88.12.594.A 022299OR

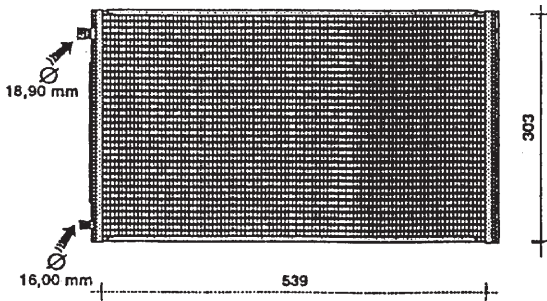

C.88.12.595.A 022300OR

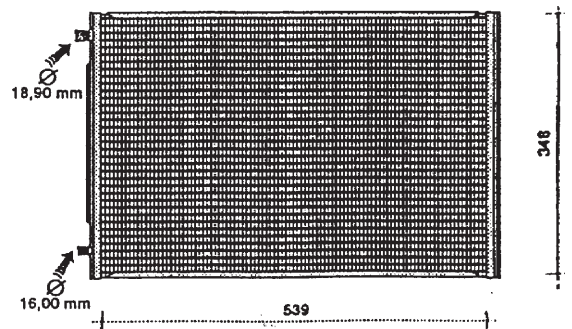

C.88.12.596.A 022301OR

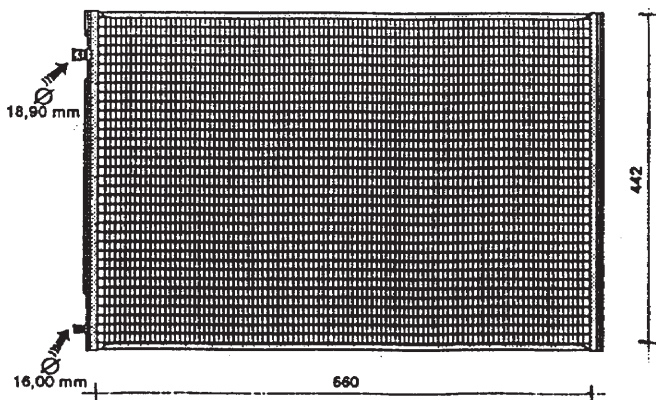

C.88.12.597.A 022417OR

FLUSSO PARALLELO
PARALLEL FLOW

3/4" - 16 UNF 2A

5/8" - 18 UNF 2A

