



*PEÇAS PARA
COMPRESSORES*

*SPARE PARTS FOR
COMPRESSORS*



3.7868
Friz. SD 7H15 std.
PV 6 ø118 Piattello incassato



3.7830
Friz. SD 7H15 std.
PV 8 ø119



C.88.15.004.A
3.7885
Friz. SD 7H15 std.
PV 6 ø120



3.7896
Friz. SD 7H15 std.
PV 6 ø132



3.9306
Friz. SD 5H14 std.
2 Gole 6" 12V



3.7401 - 3.7302
Friz. SD 7H15 std.
2 Gole 13 ø125 G-line 39.55



3.7332
Friz. SD 7H13 / 7H15 std.
2 Gole ø125 G-line 44.25



3.7172
Friz. SD 7B10
PV 6 ø100



3.7170
Friz. SD 7B10
2 Gole 13 ø115



3.7104
Friz. SD 706



3.6642 - 6631
Friz. SD 5H14 std.
2 Gole \varnothing 132



3.6629
Friz. SD 5H14 std.
PV 7 \varnothing 119 G-line 46.55



3.6332
Friz. SD 5H11 std.
2 Gole \varnothing 125 G-line 44.25



3.6323
Friz. SD 5H11 std.
PV 6 \varnothing 119 G-line 46.55



C.80.51.006.A
Friz. SD 5H14 std.
PV 6



C.80.51.007.A
Friz. SD 7H15 std.
PV 11 (5+6)



3.7150
Friz. SD 7B10
2 Gole 13 \varnothing 115



3.7829
Friz. Dedra - Tempra 1.8
2 G 13 ø143.6



3.7836
Friz. A.R. 164 TD
PV 7 ø120



3.7837
Friz. A.R. 164 R-134a
PV 5 ø135



3.7835
Friz. SD 7H15 A.R. 164 6 cil.24v
PV 7 ø130



3.7882
Friz. SD 7H15 Ducato 2.5 TD
PV 5 ø117



3.7905
Friz. SD 7H15 A.R. 155 2.5 TD
Senza campana - Voyager



3.7948
Friz. SD 7H15-24V IVECO TS
1 Gola ø135



3.7807
Friz. SD 7H15 Thema - Croma B
2 Gole ø135



3.7439
Friz. SD 709 A.R. 164 T.S. R-12
PV 5 ø135



3.1158
Friz. SD 7V16 A.R. 145/6-155/6
PV 7 ø134



3.1157
Friz. SD 7V16 A.R. 145/6-155/6
PV 6 ø134



3.1120
Friz. SD 7V16 A.R. GTV 3.0
PV 6 ø121 166 2.0 V6



3.1111
Friz. SD 7V16 A.R. 155 TS
PV 5 ø132



3.1106
Friz. SD 7V16 FIAT Ulysse
PV 6 ø120



3.7159
Friz. SD 7B10
PV 4+3



3.7418
Friz. SD 7H15 A.R. 164 3.0 V6
1 G 13+ 1 G 9.5



3.7505
Friz. SD 709 Ferrari R-12
PV 5 ø119



3.7840
Friz. SD 7H15 Ferrari R-134a
PV 5 ø119

EMBRIAGEM / CLUTCHES SANDEN O.E.M.



3.7310
Friz. SD 7H13 A.R. 145 / 146
2 Gole ϕ 125



3.7618
Friz. SD 7H15



3.9335
Friz. SD 510 New-Holland
2 Gole 10 ϕ 134 12V



3.5446
Friz. SD 508
1 Gola Ferrari

Figura non disponibile

3.1206
Friz. SD 7V16

EMBRIAGEM / CLUTCHES SEIKO



C.88.12.228.A
Friz. Seiko-Seiki SS 170 / 140
PV 6 ϕ 136



C.88.12.230.A
Friz. Seiko-Seiki SS 170 / 140
2 Gole 13 ϕ 132

 <p>C.88.15.019.A Friz. TM 13/16 2 Gole 12V</p>	 <p>C.88.15.020.A Friz. TM 13/16 2 Gole 24V</p>	 <p>C.88.15.021.A Friz. TM 13/16 PV8 ø120 12V</p>
<p><i>Figura non disponibile</i></p> <p>C.88.15.025.A Friz. TM 26 2 Gole ø156 24V</p>	 <p>C.88.15.026.A Friz. TM 13/16 PV8 ø120 24V</p>	 <p>C.88.15.028.A Friz. TM 31 2G 17 2 Gole 24V (Autobus)</p>



C.88.15.018.A
Friz. Aspera - Ferrari
1 Gola 9 60°



C.88.15.023.A
Friz. 206/209/210
2 Gole 7" 12V



C.88.15.024.A
Friz. 206/209/210
2 Gole 6" 12V

EMBRIAGEM / CLUTCHES G.M.



C.88.15.027.A
Friz. G.M. A6
1 Gola 13 24V
Completa di bobina, piattello e rotore



8.1523
Bobina SD 7H15 24V ø96
 Standard



8.0581
Bobina SD 5H11 12V
 Standard



8.0660
Bobina SD 5H14 12V
 Standard



8.1660
Bobina SD 5H14 24V
 Standard



8.0705
Bobina SD 7H15-7V16
 Con diodo



8.1523
Bobina SD 7H15 24V \varnothing 96
Connettore Packard



8.7996
Bobina SD 7H15 12V
IVECO Daily



8.9427
Bobina SD 709 12V \varnothing 102
ALFA 90 V6



8.0523
Bobina SD 7H15 12V \varnothing 96
Connettore FIAT



8.0524
Bob. SD 7H15 12V \varnothing 102 h=27
ALFA 164 3.0 V6



8.0544
Bobina SD 7H15 12V Std. \varnothing 96
Connettore AMP Maschio



8.0548
Bob. SD 7H15 12V \varnothing 102 h=30.5
ALFA / FIAT



8.0563
Bobina SD 7B10 12V
Per frizione 2 Gole \varnothing 115



8.0588
Bobina SD 7H15 12V Std. \varnothing 96
Connettore AMP Femmina

		
<p>10.7439 Piattello SD 709 A6</p>	<p>10.6320 Piattello SD 5H11</p>	<p>10.0524 ARM. Piattello SD 7H15 A3 Bullone incassato L=14.9</p>
		
<p>10.0522 ARM. Piattello SD 7H15 A3 Bullone esterno h=8</p>	<p>10.0660 Piattello SD 5H14 Standard</p>	<p>10.1158/7 Piattello SD 7V16 ALFA / FIAT</p>
		<p>10.1106 Piattello Fiat Ulisse - Scudo</p>
<p>10.0501 Piattello SD 7H15 Standard A2</p>	<p>10.9114 ARM. Piattello SD 508-510</p>	<p>10.1157 Piattello Fiat Marea - Alfa 156</p>
		<p>10.1206 Piattello VW Golf - Passat</p>
		<p>10.1215 Piattello VW Golf - Passat</p>

Figura non disponibile

62001
Paraolio SD 7B10



C.88.17.005.A
Harrison V5 / DA6
Labbro singolo

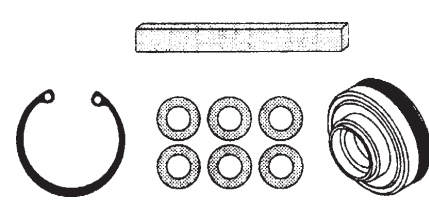

C.88.17.006.A
ND 10PA15-17-20

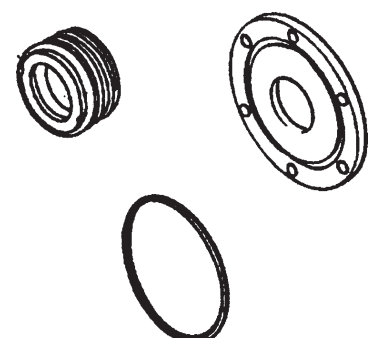

C.88.17.008.A
York

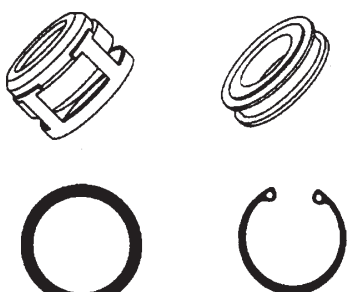

C.88.17.009.A
Seiko-Seiki SS 170 PSS

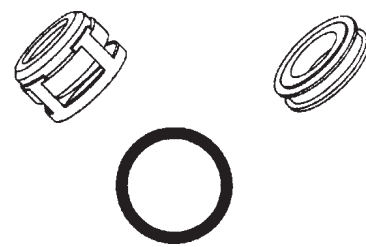

C.88.17.028.A
SD 505 R12 Viton
(solo olio minerale)

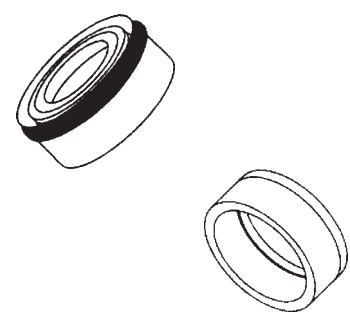

C.88.17.029.A
Kit paraolio SD 7H15-5H14-5H11
Paraolio SD 7V16 (1157-1158)
Con labbro

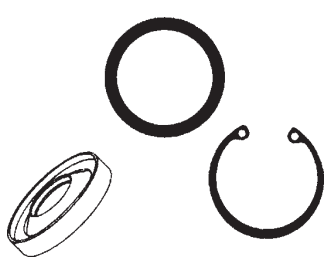

C.88.17.030.A
Diesel Kiki 26

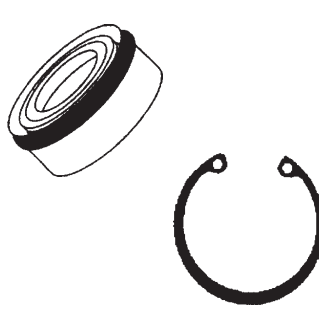

C.88.17.031.A
TM 08 - TM 16

C.88.17.032.A
Kit paraolio SD 508 / 510

C.88.17.033.A
Nippondenso 10P13-15-17

C.88.17.034.A
GM A6 / R4
In ceramica

C.88.17.035.A
GM A6 / R4
In metallo

C.88.17.036.A
Denso C171 / A590

C.88.17.037.A
ND 6P127

C.88.17.038.A
ND 6P134

C.88.17.039.A
ND 6P171

C.88.17.040.A
Ford Fx 15 / FS 10 tutti

Figura non disponibile

62001
Paraolio SD 7B10



C.88.17.005.A
Harrison V5 / DA6
Labbro singolo

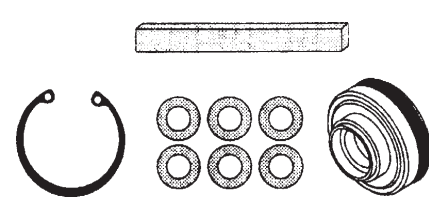

C.88.17.006.A
ND 10PA15-17-20

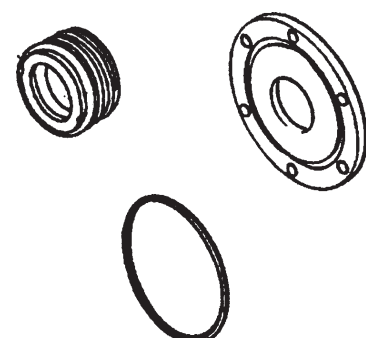

C.88.17.008.A
York

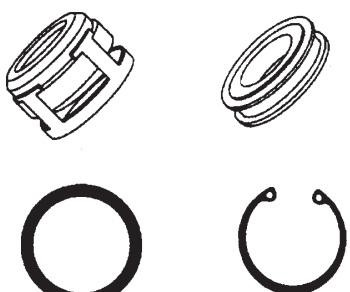

C.88.17.009.A
Seiko-Seiki SS 170 PSS

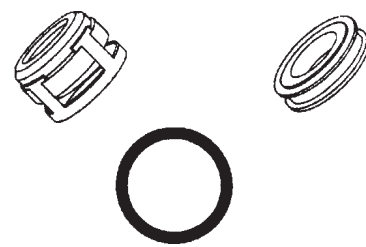

C.88.17.028.A
SD 505 R12 Viton
(solo olio minerale)

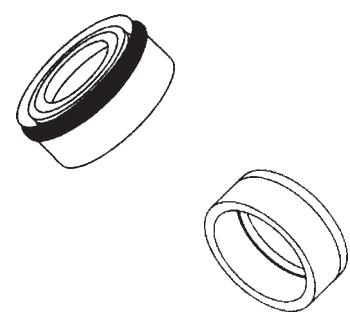

C.88.17.029.A
Kit paraolio SD 7H15-5H14-5H11
Paraolio SD 7V16 (1157-1158)
Con labbro

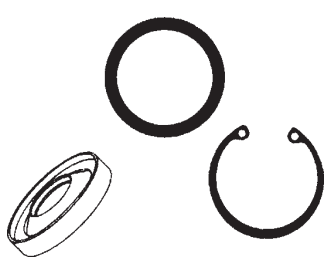

C.88.17.030.A
Diesel Kiki 26

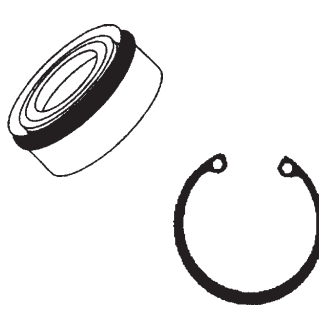

C.88.17.031.A
TM 08 - TM 16

C.88.17.032.A
Kit paraolio SD 508 / 510

C.88.17.033.A
Nippondenso 10P13-15-17

C.88.17.034.A
GM A6 / R4
In ceramica

C.88.17.035.A
GM A6 / R4
In metallo

C.88.17.036.A
Denso C171 / A590

C.88.17.037.A
ND 6P127

C.88.17.038.A
ND 6P134

C.88.17.039.A
ND 6P171

C.88.17.040.A
Ford Fx 15 / FS 10 tutti

<p><i>Figura non disponibile</i></p> <p>61001 Piastra valvole + guarnizioni SD 7B10</p>	<p><i>Figura non disponibile</i></p> <p>61005 Piastra valvole SD 5H14</p>	<p><i>Figura non disponibile</i></p> <p>61006 Piastra valvole SD 7V16</p>
<p><i>Figura non disponibile</i></p> <p>61004 Piastra valvole SD 7H15</p>		

VÁLVULAS DE CONTROLLO / CONTROL VALVES

 <p>C.88.17.068.A Valvola regolazione cil. SD 7V16</p>	 <p>C.88.17.095.A Valvola regolazione cil. SD 6V12</p>	 <p>C.88.17.096.A Valvola regolazione cil. GM V5</p>
---	---	---

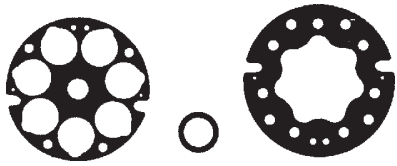

67010
Kit guarniz. SD 7H13-7H15
In ferro



67011
Kit guarniz. Piastra/Testa valvole
SD 7V16

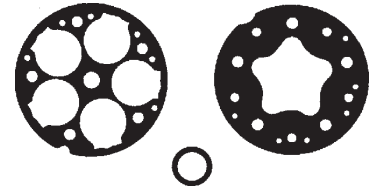

67012
Kit guarniz. SD 5H11-5H14
In ferro

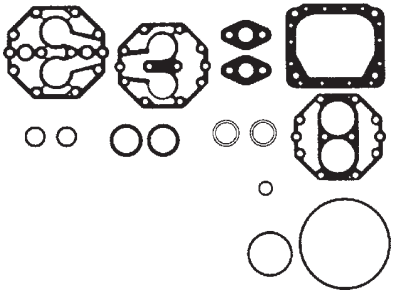

C.88.17.017.A
21-24602
Kit guarniz. York

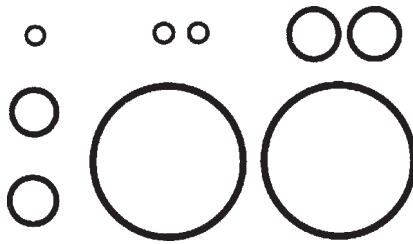

C.88.17.018.A
21-24607
Kit O.Ring GM A6

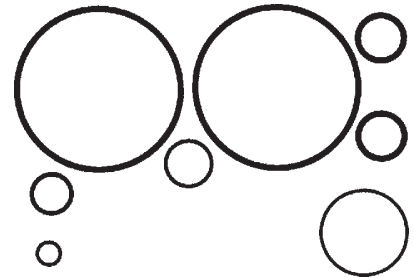

C.88.17.019.A
21-24608
Kit O.Ring GM R4 O.Ring

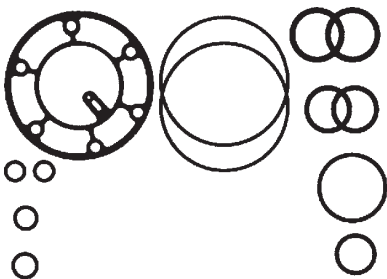

C.88.17.020.A
21-24610
Kit guarniz. + O.Ring GM V5

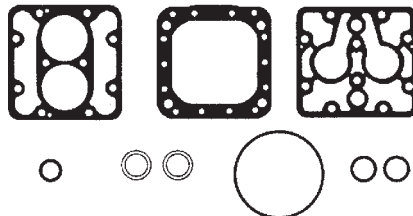

C.88.17.021.A
21-24612
Kit guarniz. + mini O.Ring York

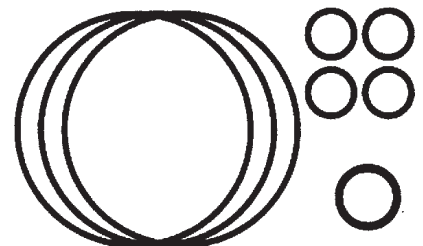

C.88.17.022.A
21-24617
Kit O.Ring ND 10P13A ECT.

C.88.17.023.A
21-24618
Kit guarniz.+ O.Ring ND 6E171

C.88.17.024.A
21-24619
Kit guarniz.+ O.Ring ND 6E171A

C.88.17.025.A
21-24620
Kit guarniz.+ O.Ring ND 6P127

C.88.17.026.A
21-24621
Kit guarniz.+ O.Ring ND 6P134

C.88.17.027.A
21-24633
Kit guarniz.+ O.Ring Ford FX 15

C.88.17.049.A
21-24648
Kit guarniz.+ O.Ring ND 6P148A

C.88.17.050.A
21-24649
Kit guarn.+ O.Ring ND 10PA17A

Figura non disponibile

C.88.17.051.A
21-24650
Kit guarn.+ O.Ring ND 10PA15A

C.88.17.070.A
21-24667
Kit guarn.+ O.Ring ND TV 12C

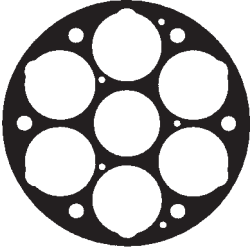
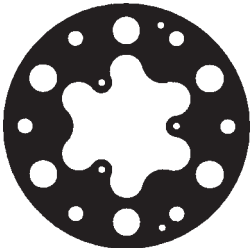
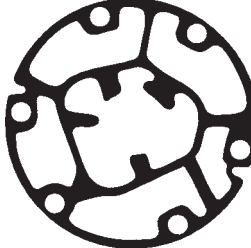
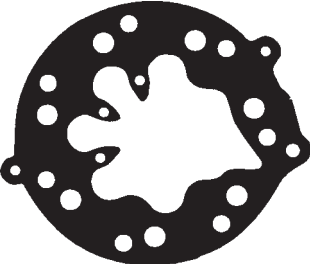
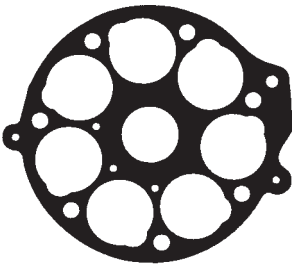
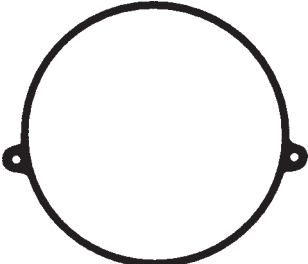
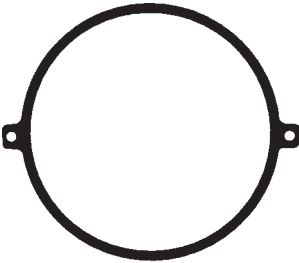
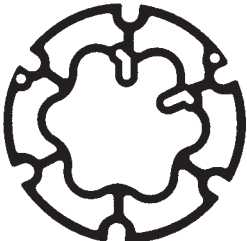
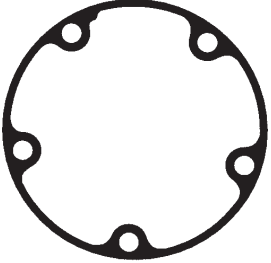
 <p>C.88.17.075.A Guarnizione cilindri SD6V12</p>	 <p>C.88.17.076.A Guarniz. piastra valvole SD6V12</p>	 <p>C.88.17.077.A Guarnizione TM15HD</p>
 <p>C.88.17.078.A Guarniz. piastra valvole ND7SB16C</p>	 <p>C.88.17.079.A Guarnizione cilindri ND7SB16C</p>	 <p>C.88.17.080.A Guarnizione ND7SB16C</p>
 <p>C.88.17.081.A Guarnizione posteriore DELPHI CVC</p>	 <p>C.88.17.082.A Guarnizione anteriore DELPHI CVC</p>	 <p>C.88.17.083.A Guarnizione ND SC08</p>

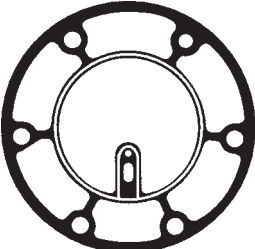

C.88.17.084.A
Guarnizione GM V5

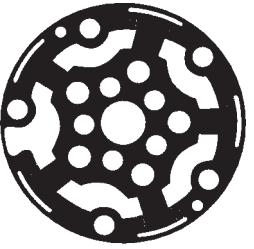

C.88.17.085.A
Guarnizione anteriore ND 10PA15C/17C

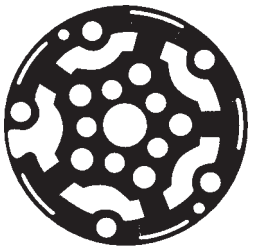

C.88.17.086.A
Guarnizione posteriore ND 10PA15C/17C

(1993 & UP)

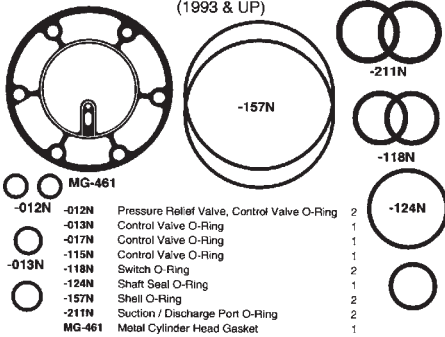

C.88.17.087.A
Kit guarnizioni GM V5

MG-461			
-012N	-012N	Pressure Relief Valve, Control Valve O-Ring	2
-013N	-013N	Control Valve O-Ring	1
-017N	-017N	Control Valve O-Ring	1
-019N	-019N	Control Valve O-Ring	1
-115N	-115N	Control Valve O-Ring	1
-118N	-118N	Switch O-Ring	2
-124N	-124N	Shaft Seal O-Ring	1
-157N	-157N	Shell O-Ring	2
-211N	-211N	Suction / Discharge Port O-Ring	2
MG-461	MG-461	Metal Cylinder Head Gasket	1

(GM #2724887)

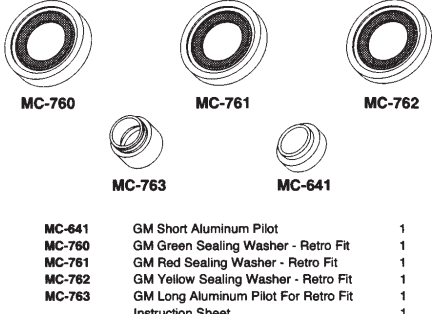

C.88.17.088.A
Kit guarnizioni GM Retro fit

MC-641	MC-641	GM Short Aluminum Pilot	1
MC-760	MC-760	GM Green Sealing Washer - Retro Fit	1
MC-761	MC-761	GM Red Sealing Washer - Retro Fit	1
MC-762	MC-762	GM Yellow Sealing Washer - Retro Fit	1
MC-763	MC-763	GM Long Aluminum Pilot For Retro Fit	1
		Instruction Sheet	1

DIESEL KIKI DCW-17 O-RING / GASKET KIT

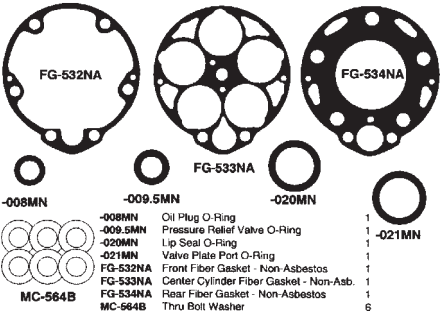

C.88.17.089.A
Kit guarnizioni DCW-17

MC-564B	MC-564B	Thru Bolt Washer	6
-008MN	-008MN	Oil Plug O-Ring	1
-009.5MN	-009.5MN	Pressure Relief Valve O-Ring	1
-020MN	-020MN	Lip Seal O-Ring	1
-021MN	-021MN	Valve Plate Port O-Ring	1
FG-532NA	FG-532NA	Front Fiber Gasket - Non-Asbestos	1
FG-533NA	FG-533NA	Center Cylinder Fiber Gasket - Non-Asb.	1
FG-534NA	FG-534NA	Rear Fiber Gasket - Non-Asbestos	1
-021MN	-021MN		1

SELTEC TM-15HD O-RING / GASKET KIT

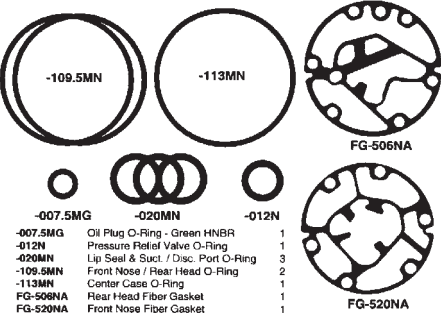

C.88.17.090.A
Kit guarnizioni TM 15

FG-506NA	FG-506NA		
FG-520NA	FG-520NA		
-007.5MG	-007.5MG	Oil Plug O-Ring - Green HNBR	1
-012N	-012N	Pressure Relief Valve O-Ring	1
-020MN	-020MN	Lip Seal & Suct. / Disc. Port O-Ring	3
-109.5MN	-109.5MN	Front Nose / Rear Head O-Ring	2
-113MN	-113MN	Center Case O-Ring	1
FG-508NA	FG-508NA	Rear Head Fiber Gasket	1
FG-520NA	FG-520NA	Front Nose Fiber Gasket	1

CHRYSLER / MERCEDES 6CA17C, 6CA17K O-RING / GASKET KIT

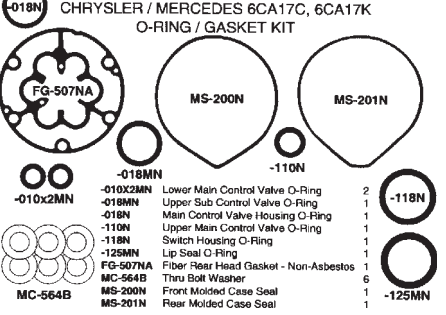

C.88.17.091.A
Kit guarnizioni ND6CA17C MB

MC-564B	MC-564B	Thru Bolt Washer	6
-018N	-018N	Lower Main Control Valve O-Ring	2
-010x2MN	-010x2MN	Upper Sub Control Valve O-Ring	1
-018MN	-018MN	Main Control Valve Housing O-Ring	1
-110N	-110N	Upper Main Control Valve O-Ring	1
-118N	-118N	Switch Housing O-Ring	1
-125MN	-125MN	Lip Seal O-Ring	1
FG-507NA	FG-507NA	Fiber Rear Head Gasket - Non-Asbestos	1
MC-564B	MC-564B	Thru Bolt Washer	6
MS-200N	MS-200N	Front Molded Case Seal	1
MS-201N	MS-201N	Rear Molded Case Seal	1
-118N	-118N		1
-125MN	-125MN		1

NIPPONDENSO 10PA15C (MERCEDES) O-RING KIT

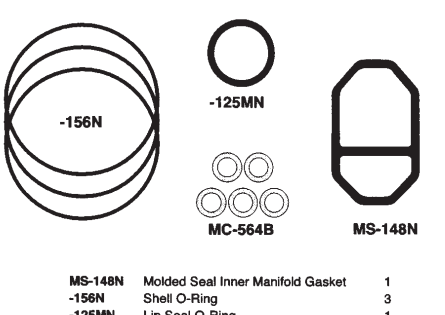

C.88.17.092.A
Kit guarnizioni ND10PA15C MB

MS-148N	MS-148N	Molded Seal Inner Manifold Gasket	1
-156N	-156N	Shell O-Ring	3
-125MN	-125MN	Lip Seal O-Ring	1
MC-564B	MC-564B	Thru Bolt Washer	5

O-RING KIT

MS-145N	-114X3MN Shell O-Ring	3	-125MN	-125MN Lip Seal O-Ring	1
-015MN	-125MN Lip Seal O-Ring	1	MC-145N	MC-145N Molded Seal Inner Manifold Gasket	1
	MC-564B Thru Bolt Washer	5	-015MN	-015MN Sensor Plug O-Ring	1
			MC-564B	MC-564B Thru Bolt Washer	5

C.88.17.093.A
Kit guarnizioni ND10PA20C

NIPPONDENSO 7SB-16C O-RING / GASKET KIT

-009.5MN	-009.5MN Lower Control Valve O-Ring	1	MS-213N	MS-213N Molded Manifold Seal	1
-010MN	-010MN Center Control Valve O-Ring	1	FG-525NA	FG-525NA Fiber Valve Plate Gasket - Non-Asbestos	1
-018N	-018N Upper Control Valve O-Ring	1	FG-526NA	FG-526NA Fiber Cylinder Block Gasket - Non-Asb.	1
-020MN	-020MN Lip Seal O-Ring	1	FG-527NA	FG-527NA Fiber Front Shell Gasket - Non-Asbestos	1
-119N	-119N Suction Fitting Pilot O-Ring	1	MC-564B	MC-564B Thru Bolt Washers	7
	-905G Discharge Fitting Pilot O-Ring	2			

C.88.17.094.A
Kit guarnizioni ND7SB16C

PARAFUSOS / BOLTS

C.88.17.052.A
Bullone testa SD 7V16
L=48

63007-7552-0470
Bullone SD 7H15
L=40

6620-0470
Bullone SD 5H14 / 11
L=48

7702-0470
Bullone SD 7H15
L=58

63015-1010-0471
Bullone SD 7V16
L=45

1100-0471
Bullone SD 7V16
L=53

	<p><i>Cuscinetto per:</i></p> <p><i>Sanden : SD 507 / 508 / 510 SD 5H14</i></p> <p><i>Seiko : SS 170 / 140 / 121</i></p> <p><i>Nihon : DKV 14 C</i></p> <p><i>Hitachi : MJS 170</i></p> <p><i>Misure : ø40 x ø62 x h24</i></p> <p> </p> <p><i>7.9396</i></p>	<p><i>Cuscinetto per:</i></p> <p><i>Sanden : SD 505 / 708 / 709 SD 7H15-7H13-7V16</i></p> <p><i>Diesel Kiki : TR 90</i></p> <p><i>Seltec : TM 15</i></p> <p><i>Matsushita : SA - ML</i></p> <p><i>Nihon : DKV 11A - DKV 14 A-C-D</i></p> <p><i>Misure : ø35 x ø55 x h20</i></p> <p> </p> <p><i>7.9422</i></p>
<p><i>Cuscinetto per:</i></p> <p><i>Denso : 10PA15 / A17 / A20</i></p> <p><i>Denso : TV12SC - TV12EC TV12C - TV14</i></p> <p><i>Misure : ø30 x ø52 x h22</i></p> <p> </p> <p><i>C.88.17.014.A</i></p>	<p><i>Cuscinetto per:</i></p> <p><i>Denso : 7SB - 16C - 6CA</i> <i>(Lancia k - Rover 820/825 - BMW E-39 - OPEL Omega TD - Mercedes W 202 / 210)</i></p> <p><i>Delphi : HV6 - CVC</i></p> <p><i>Misure : ø35 x ø52 x h22</i></p> <p> </p> <p><i>C.88.17.015.A</i></p>	<p><i>Cuscinetto per:</i></p> <p><i>Delphi : A6 - R4 - DA6 - HR6 - HR6HE - HT6 - V5 - V7</i></p> <p><i>Keihin : 150R - 150L</i></p> <p><i>Seiko Seiki : alcune applicazioni</i></p> <p> </p> <p><i>Misure : ø40 x ø62 x h20.6</i></p> <p> </p> <p><i>C.88.17.016.A</i></p>
<p><i>Cuscinetto per:</i></p> <p><i>Fs - Fx :</i> <i>Ford</i></p> <p> </p> <p><i>Misure : ø30 x ø55 x h23</i></p> <p> </p> <p><i>C.88.17.059.A</i></p>	<p><i>Cuscinetto per:</i></p> <p><i>York : ø6" x ø7" Warner</i></p> <p> </p> <p><i>Misure : ø30 x ø62 x h16</i></p> <p> </p> <p><i>C.88.17.060.A</i></p>	<p><i>Cuscinetto per:</i></p> <p><i>ND : SC 06</i></p> <p> </p> <p><i>Misure : ø30 x ø52 x h20</i></p> <p> </p> <p><i>C.88.17.071.A</i></p>
<p><i>Cuscinetto per:</i></p> <p><i>ND : BMW-Fiat-MB-Opel-Rover</i></p> <p> </p> <p><i>Misure : ø35 x ø52 x h23</i></p> <p> </p> <p><i>C.88.17.072.A</i></p>	<p><i>Cuscinetto per:</i></p> <p><i>Toyota</i></p> <p> </p> <p><i>Misure : ø35 x ø52 x h20</i></p> <p> </p> <p><i>C.88.17.073.A</i></p>	<p><i>Cuscinetto per:</i></p> <p><i>TRS-090 - SD7B10 - Mitsubishi</i></p> <p> </p> <p><i>Misure : ø35 x ø50 x h20</i></p> <p> </p> <p><i>C.88.17.074.A</i></p>

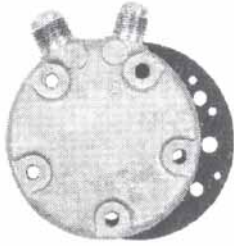

E 9.cono
Verticali
G10 - Cono 7/8"
G8 - Cono 3/4"
5H09-5H11-5H14

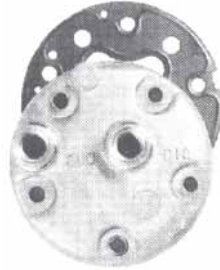

M 9.9699
Orizzontali
Rotolock 1" 14
Rotolock 1" 14
5H14

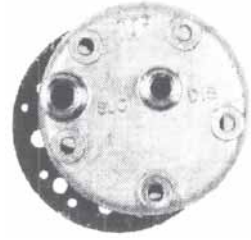

K 9.6634
Orizzontali
G10 - O.Ring 7/8"
G8 - O.Ring 3/4"
5H14

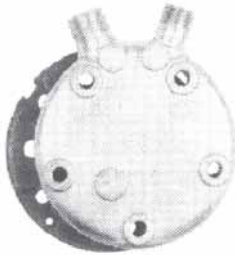

FL 9.6621
Verticali
G10 - O.Ring 7/8"
G8 - O.Ring 3/4"
5H14

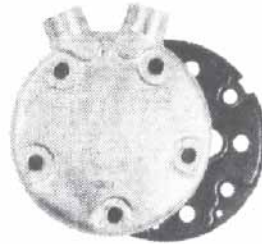

C 9.8476
Verticali
Rotolock 1" 14
Rotolock 1" 14
5H14



KG 9.7862
Orizzontali
G10 - O.Ring 7/8"
G8 - O.Ring 3/4"
7H13-7H15







CB 9.7412
Verticali
Rotolock 1" 14
Rotolock 1" 14
7H13-7H15



CD 9.7446
Verticali / Spessa
Rotolock 1" 14
Rotolock 1" 14
7H13-7H15

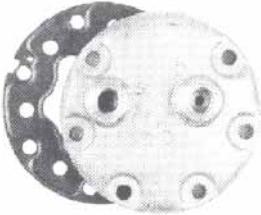
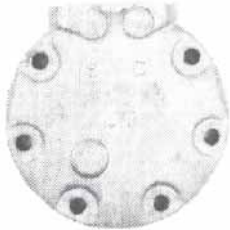

JE 9.7863
Verticali
G10 - O.Ring 7/8"
G8 - O.Ring 3/4"
7H13-7H15

 <p>MD 9.7477 Orizzontali Rotolock 1" 14 Rotolock 1" 14 7H13-7H15</p>	 <p>UK 9.7200 Verticali Flangia - M10x1.25 Flangia - M10x1.25 7H13-7H15</p>	<p><i>Figura non disponibile</i></p> <p>MH 9.7449 Orizzontale Testata alta Rotolock 1" 14 Rotolock 1" 14</p>
 <p>VUA 9.1111 Verticali Flangia Flangia 7V16</p>	 <p>VQA 9.1106 Orizzontale Testata alta Flangia Flangia</p>	 <p>VUC 9.1157 Verticali Flangia Flangia 7V16</p>



C.88.17.001.A
Raccordo TM
O.R. Rotolock orizzontale



C.88.17.002.A
Raccordo TM
O.R. Rotolock verticale



C.88.17.003.A
Raccordo TM
O.R. verticale + Vs



C.88.17.004.A
Raccordo TM
O.R. orizzontale



C.88.17.058.A
Raccordo TM
O.R. verticale



C.88.17.012.A
Raccordo York
Rotolock / O.R. G8



C.88.17.013.A
Raccordo York
Rotolock / O.R. G10



C.88.17.010.A
Raccordo York
Rotolock / Cono G8



C.88.17.011.A
Raccordo York
Rotolock / Cono G10