

## Hydraulically or pneumatically actuated

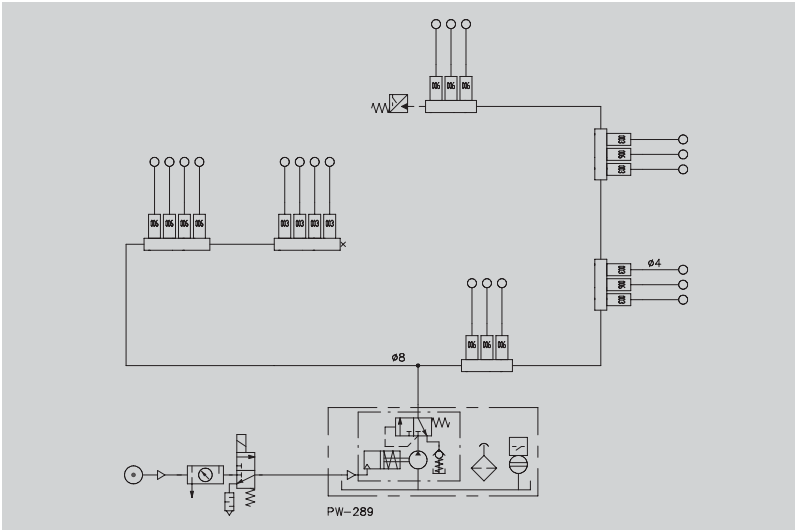

Piston pump PW-289

These pumps are designed for single-line centralized lubrication systems (total-loss lubrication) and are outfitted with a pressure relief device need for proper functioning of the distributors, i.e. the main line between the pump and distributors is automatically relieved of pressure after the pump piston's return stroke.

These pumps are preferred when remote control is desired or when the lubrication system is to be automated. Time- or load-dependent control systems are possible. Pressurized oil or compressed air is required in every case.

When the pump is running, the metered quantities of oil in the distributors are fed to the lube points via the secondary lines.

### Selecting the pump

The selection is made on the basis of the

- required delivery rate,
- capacity of the planned system,
- type of actuation used and its pressure.

The system capacity consists of:

- the sum of all the metered distributor quantities in the system,
- + 25 % of this value,
- + 1 ccm per meter of flexible main line (breathing loss).

To ensure a pressure build-up, the system capacity should not exceed 2/3 the delivery rate/stroke of a piston pump.

The total amount of oil required can be met in a number of ways by varying the delivery rate, the metered distributor quantities and the lubrication frequency.

### Start-up and maintenance of a system

Fill the reservoir with oil and actuate the pump at intervals of 2-3 seconds one after another until oil emerges at all the lube points.

A properly laid out system will bleed itself on its own!

The bleeding process is enhanced by

- opening the ends of the main line until bubble-free oil emerges there.
- filling long secondary lines - especially ones leading to distributors with small metered quantities - before they are connected to the lube point.

Maintenance involves:

1. Checking the oil level and topping up in good time!  
Using brand-name oil in accordance with the machine manufacturer's instructions. Unless otherwise indicated, choose an oil with a rated viscosity ranging from 15-150 mm<sup>2</sup>/s at 40 °C. Always use a strainer when topping up oil!
2. After the machine has run for an extended period of time, retighten all the tubing unions and actuate the pump to check whether oil emerges at all the lube points.

Only use original spare parts from VOGEL.

Never clamp a pump in a vise!

**Piston pump, hydraulically actuated, with reservoir (for oil)**

The effective reservoir capacity has been dimensioned to cover the needs of 3-4 weeks operation when actuated twice a day. But it is advisable to top up the reservoir on a weekly basis.

Every pump has two – alternatively usable – pressure ports (P2) opposite each other, one of which is closed at the factory before delivery.

**7 ccm/stroke**

**Reservoir capacity 0.4 l**

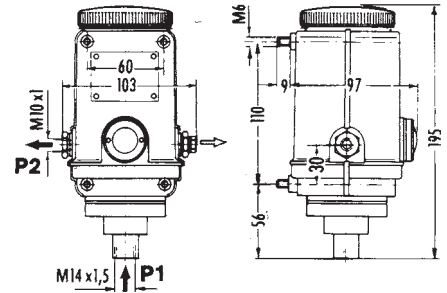

**P1 = port** for actuating medium  
**P2 = outlet,** port for centralized lubrication system

Order No.	Delivery rate [ccm/stroke]	Reservoir capacity [liters]	p1 permissible for distributor systems [bars]	Volume required for P1 [ccm/stroke]
<b>P-38-4</b>	7	0.4	15 - 35	7

Ports tapped for solderless tube connection: M10x1 for ø6 tubing, M14x1,5 for ø8 tubing. See diagram on page 4 for pressure ratios.

**Piston pump, pneumatically actuated, with reservoir (for oil)**

**10 ccm/stroke**

**Reservoir capacity 1.5 l**

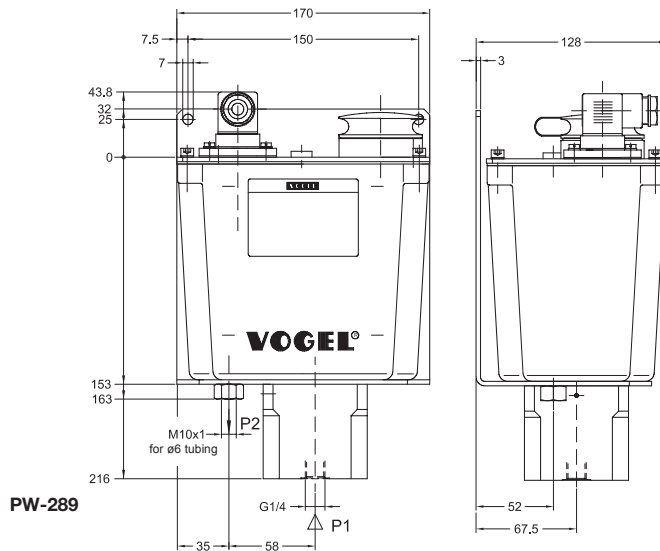

Graphic symbols

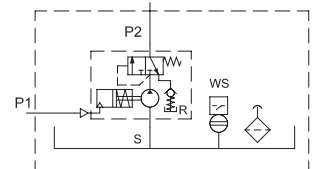

Order No.	Delivery rate [ccm/stroke]	Reservoir capacity [liters]	p1 permissible for distributor systems [bars]	Volume required for P1 [ccm/stroke]	with built-in float switch order No.
<b>P-289</b>	10	1.5	3.5 - 10	53	<b>PW-289</b>

Ports tapped for solderless tube connection: M10x1 for ø6 tubing. See diagram on page 4 for pressure ratios.

A safety valve must be provided for to protect the system; e.g. **WVN200-6B40**, opening pressure 40 bars.

**P1 = port** for actuating medium  
**P2 = outlet,** port for centralized lubrication system

**Piston pump, pneumatically actuated, with reservoir (for oil or grease, NLGI grades 000, 00, 0)**

**48 ccm/stroke**

**Reservoir capacity 3 l**

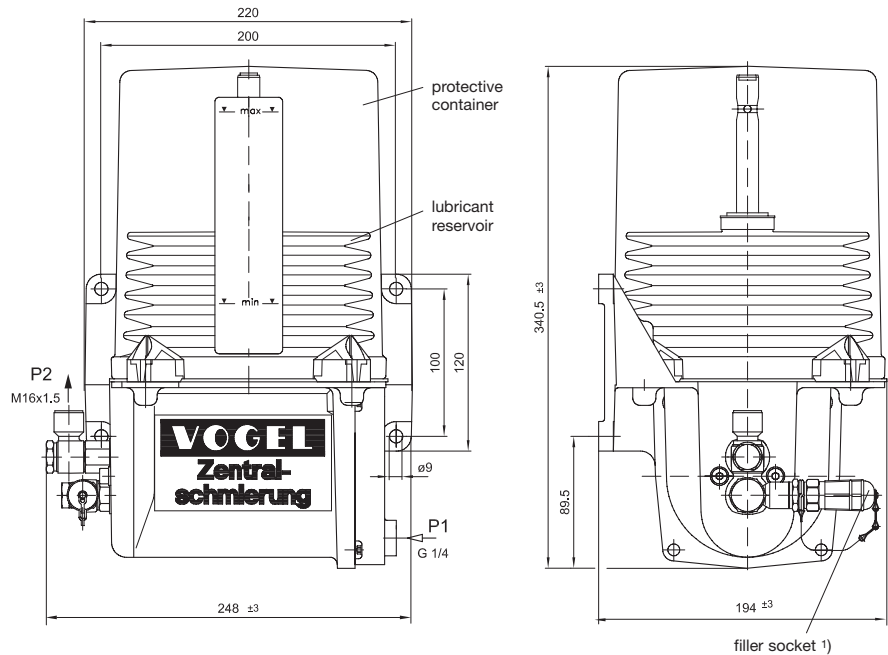

Order No.	Delivery rate [ccm/stroke]	Reservoir capacity [liters]	Permissible air pressure p1 for pump actuation [bars]	Mounting position	Lubricant
PEF-90	48	3	6 - 10	as shown	oil or grease, NLGI grade 000, 00, 0

Make sure the pump is installed without distortion!

- 1) Lubricant is filled with an external topping-up pump via the filler socket. The line used to connect the topping-up pump must be equipped with a coupling socket, order No. 995-001-500. Topping-up pump on request.

**Ports**

- P1** = for air line from compressed air reservoir  
 respective **adapter** for ø6 tubing: order No. 406-054  
**sealing ring**: order No. 508-108
- P2** = for main line to system  
 respective **adapter** for ø 8 tubing: order No. 408-005  
 for ø10 tubing: order No. 410-004  
**sealing ring**: order No. DIN7603-A16x20-CU  
**banjo union** for ø10 tubing: order No. 510-145  
**sealing ring**: order No. DIN7603-A16x20-CU

**Pressure ratio p1 : p2 for PEF-90 and working ranges of oil and grease distributors**

Working ranges for the following distributor groups

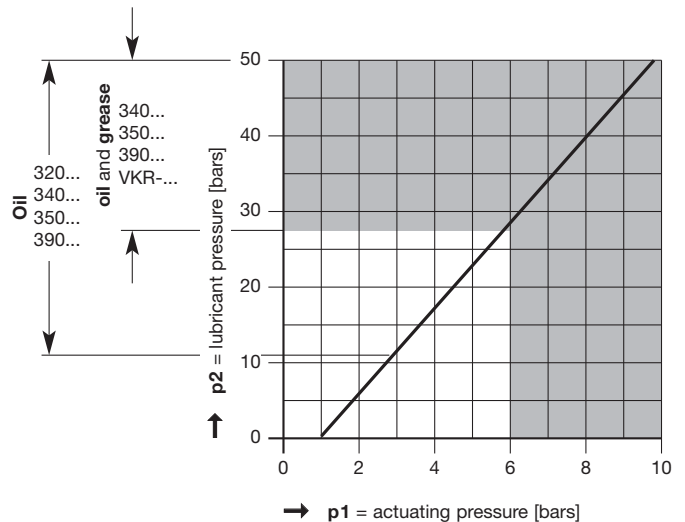

**Graphic symbols**

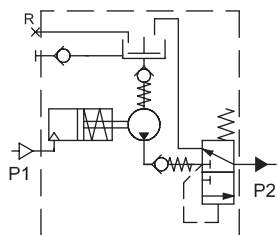

Dimensions in mm

Pressure ratio  $p_1 : p_2 = \text{actuating pressure} : \text{lubricant pressure}$

(oil)

Hydraulically actuated pump P-38-4

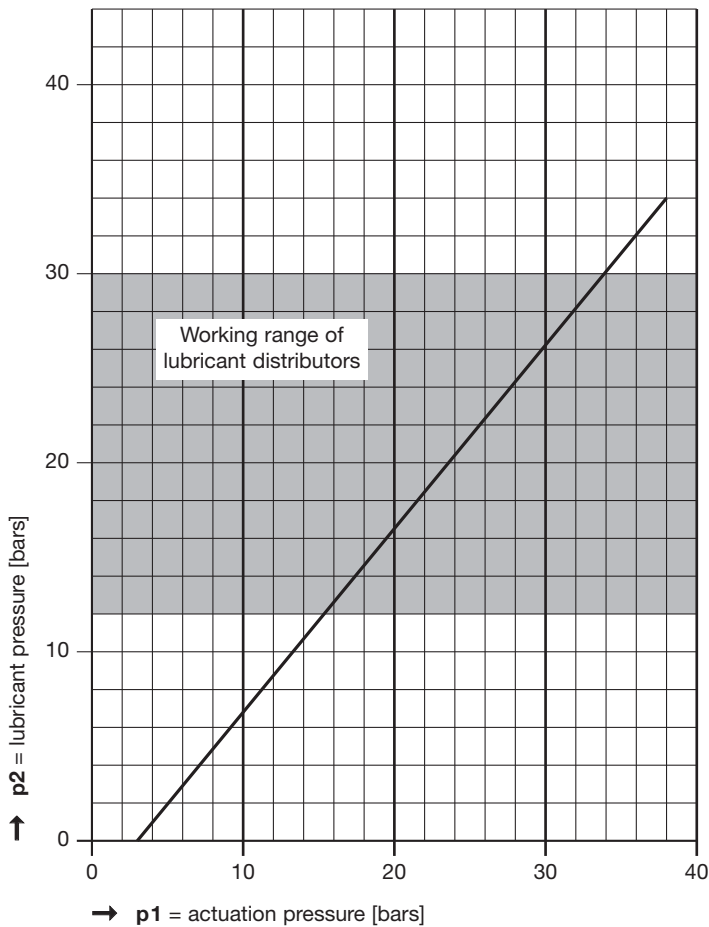

Pneumatically actuated pump P-289

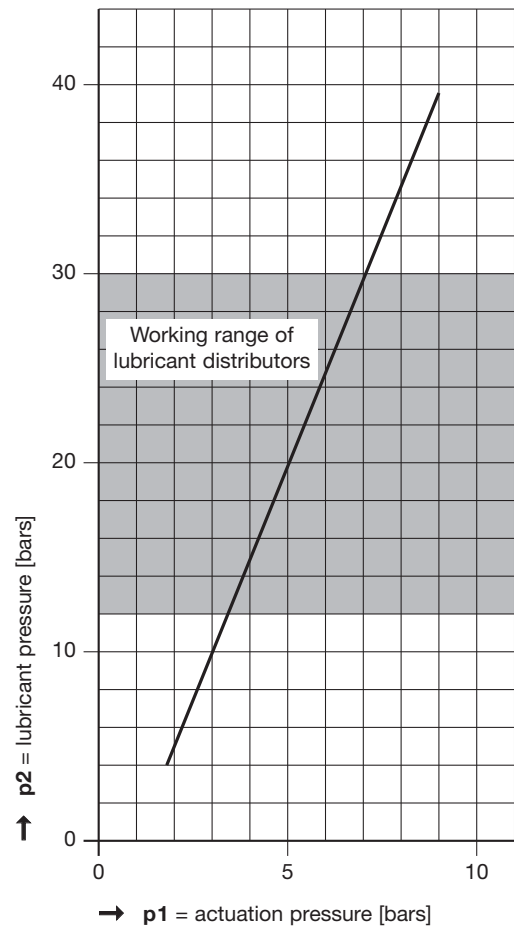

**Leaflet information**

- 1-5001-US: Piston Distributors for Oil
- 1-0015-US: Piston Distributors for Grease
- 1-1700-US: Control and Monitoring Units
- 1-1701-US: Pressure Switches
- 1-1703-US: Directional Control Valves

**Notice!**

All products from VOGEL may be used only for their intended purpose. If operating instructions are supplied together with the products, the provisions and information therein of specific relevance to the equipment must be observed as well.

In particular, we call your attention to the fact that hazardous materials of any kind, especially the materials classified as hazardous by EC Directive 67/548/EEC, Article 2, Par. 2, may only be filled into VOGEL centralized lubrication systems and components and delivered and/or distributed with the same after consultation with and written approval from VOGEL.

All products manufactured by VOGEL are not approved for use in conjunction with gases, liquefied gases, pressurized gases in solution and fluids with a vapor pressure exceeding normal atmospheric pressure (1013 mbars) by more than 0.5 bar at their maximum permissible temperature.



A brand of the SKF Group

**Willy Vogel AG**  
 Motzener Strasse 35/37  
 12277 Berlin, Germany  
 P.O. Box 970444 · 12704 Berlin  
 Tel. +49 (0) 30 72002-0  
 Fax +49 (0) 30 72002-111  
 info@vogel-berlin.de  
 www.vogelag.com

**Willy Vogel AG**  
 2. Industriestrasse 4  
 68766 Hockenheim  
 Germany  
 Tel. +49 (0) 6205 27-0  
 Fax +49 (0) 6205 27-132  
 info@vogel-berlin.de  
 www.vogelag.com

**Vogel France SAS**  
 Rue Robert Amy, B.P. 70130  
 49404 Saumur cedex  
 France  
 Tel. +33 (0) 241 404 200  
 Fax +33 (0) 241 404 242  
 info@vogelfrance.com  
 www.vogelfrance.com