

Single-Line Centralized Lubrication Systems

1-0015-US

For fluid grease, NLGI grades 000, 00



PFE-15-0.5



PF-289



MFE2-KW6F-S1

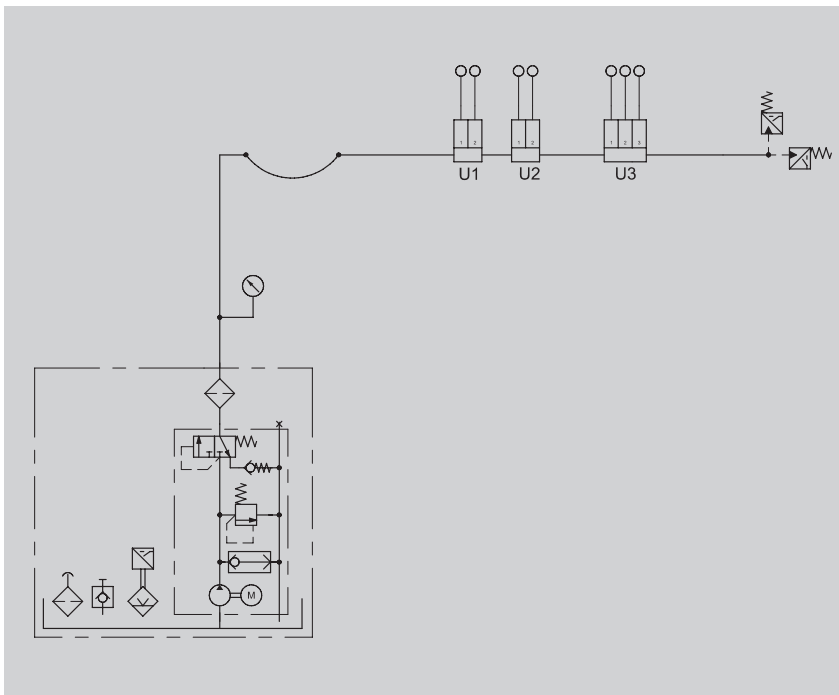

Grease is frequently used as the lubricant whenever dripping oil might cause problems, but the advantages of a single-line centralized lubrication system are nevertheless wanted.

The layout of a single-line centralized lubrication system for grease is largely similar to that of a single-line centralized lubrication system for oil.

To ensure a pressure build-up, the system capacity should not exceed 2/3 the delivery rate/stroke of a piston pump

Applications

- gantries on transfer lines
- recirculating roller elements
- injection molding machines (knee levers)

PFE / PFEP – plunger pumps, manually or pneumatically actuated

These manually or pneumatically actuated plunger pumps were developed for intermittently operated, single-line centralized lubrication systems with piston distributors. They come with the set of valves required for pressure relief and pressure limitation.

The lubricant reservoirs made of transparent plastic are available in three different sizes: 0.5; 1.0 or 1.7 liters.

Versions with / without warning switches for the monitoring of critical levels of grease.

Startup

Fill the reservoir with fluid grease and operate the pump at intervals of 2-3 seconds until lubricant emerges at every lube point.

A properly laid system will vent itself!

The venting procedure is helped by

- opening the ends of the main lines until fluid grease emerges there,
- filling long secondary lines
 - especially from distributor ports with small metered quantities – before connecting them to the lube point.

Maintenance

1. Check the level of fluid grease and top up the reservoir in good time!
Use lubricant that conforms to the machine manufacturer's instructions.
2. After the machine has run for an extended period of time check all the tubing connections for tight fits and actuate the pump to check whether lubricant emerges at all the lube points.

Only use original VOGEL spare parts.

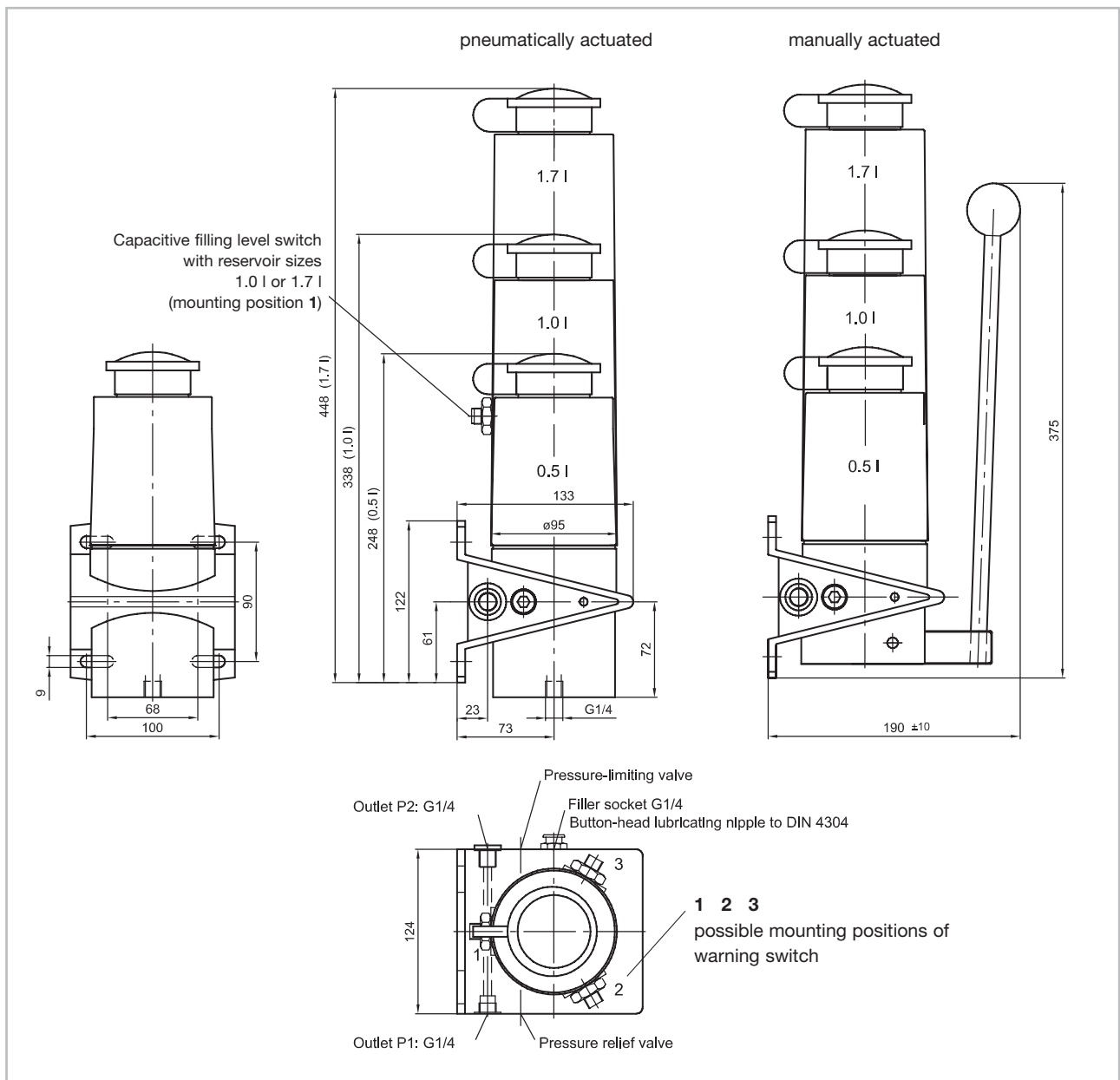

Technical data

Pump

- Drive manual or pneumatical
- Reservoir capacity 0.5 l, 1.0 l and 1.7 l
- Reservoir material plastic (PP), transparent
- Outlet ports G 1/4, left or right
- Compressed air port G 1/4 (on bottom of pump)
- Max. operating pressure 30 bars (manual operation)
60 bars (pneum. operation)
- Delivery rate per stroke 15 ccm
- Actuating air volume =
delivery rate x pressure-limiting valve x pressure [bars]
- Ambient temperature 0 to +60 °C

Lubricant fluid grease,
NLGI grades 000 to 0

Pressure chart for pneumatic drive

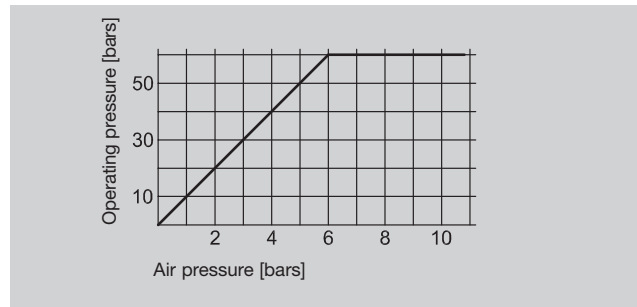

Please note!
Cutting-sleeve screw unions conforming to DIN 2353 or VOGEL quick connectors have to be used as connection fittings when the system's hydraulic pressure exceeds 45 bars.

Warning switch

for monitoring of min. grease level

- Function PNP / NO-NC
- Switched voltage 10 ... 36 V DC
- Load current at switch output max. 150 mA
- Type of enclosure IP 67
- Connection 2m PVC cable or
4-pole circular plug M8x1
- Mounting position 1, 2 or 3 possible;
from factory in mounting pos. 2

Circuit

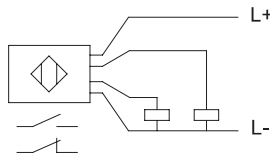

Hydraulic layouts

PFEP (pneumatic)

PFE (manual)

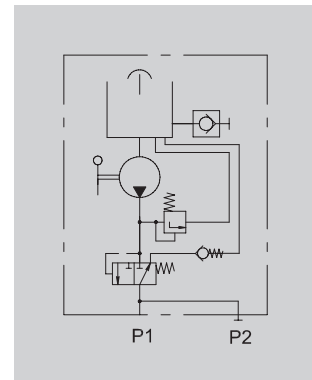
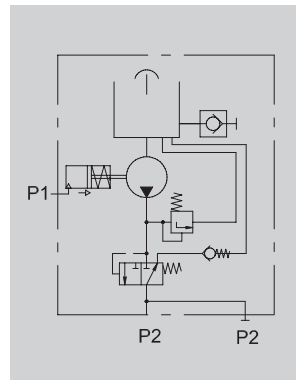

without warning switch Order No.	with warning switch Order No.	Delivery rate [ccm/stroke]	Reservoir capacity [liters]	Drive	Max. operating pressure (pressure limiting valve) [bars]
PFE-15-0.5	–	15	0.5	manual	30
PFEP-15-0.5	–	15	0.5	pneumatic	60
PFE-15-1.0	PFE-15-1.0W1(2) 1)	15	1.0	manual	30
PFEP-15-1.0	PFEP-15-1.0W1(2) 1)	15	1.0	pneumatic	60
PFE-15-1.7	PFE-15-1.7W1(2) 1)	15	1.7	manual	30
PFEP-15-1.7	PFEP-15-1.7W1(2) 1)	15	1.7	pneumatic	60

1) ...W1 = warning switch connection 2 m PVC cable; ...W2 = warning switch connection 4-pole circular plug, M8x1

PF-289 – piston pump, pneumatically actuated

Function

The pumps are pressurized with compressed air via a 3/2-way valve.

The delivery piston is moved by the pneumatic actuating piston and the quantity of lubricant deposited in the pump chamber is discharged. The system pressure required for the delivery of grease is reached as a result of the area ratio of the actuating piston to the delivery piston.

After a lubrication routine is completed the actuating piston has to be relieved of pressure so that the connected distributors can reverse and be refilled for the next lubrication pulse.

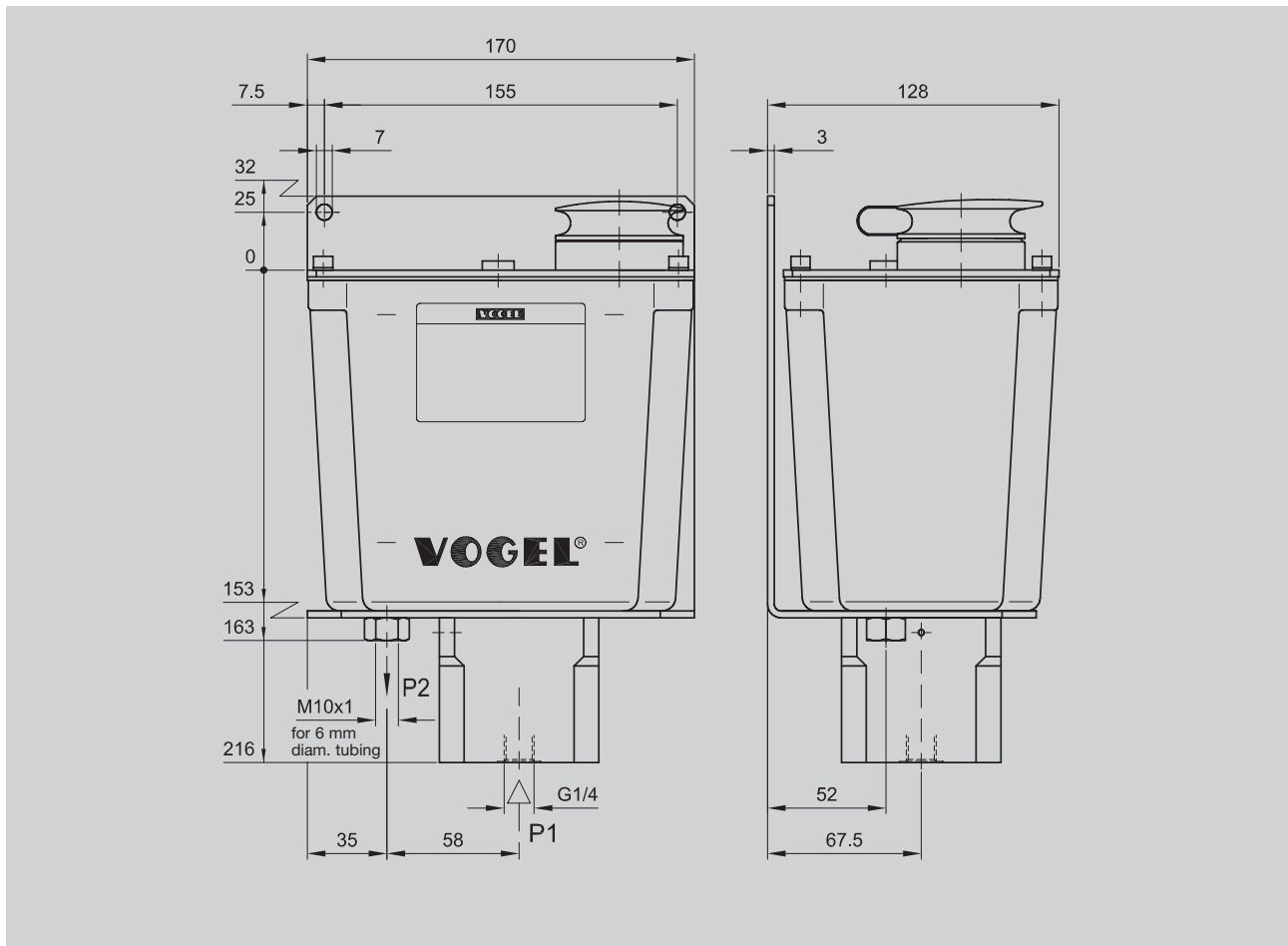

Technical data

Order No.	PF-289
Delivery rate per stroke	10 ccm
Area ratio (actuating piston/delivery piston)	4.9 : 1
Actuating pressure	3.5 - 10 bars
Reservoir capacity	1.5 liters
Mounting position	vertical
Lubricant	fluid grease, NLGI grades 000, 00

P1 = pressure port

P2 = pressure port to system

Ports tapped for solderless tube connection.

PEF-99W-S3 – piston pump, pneumatically actuated

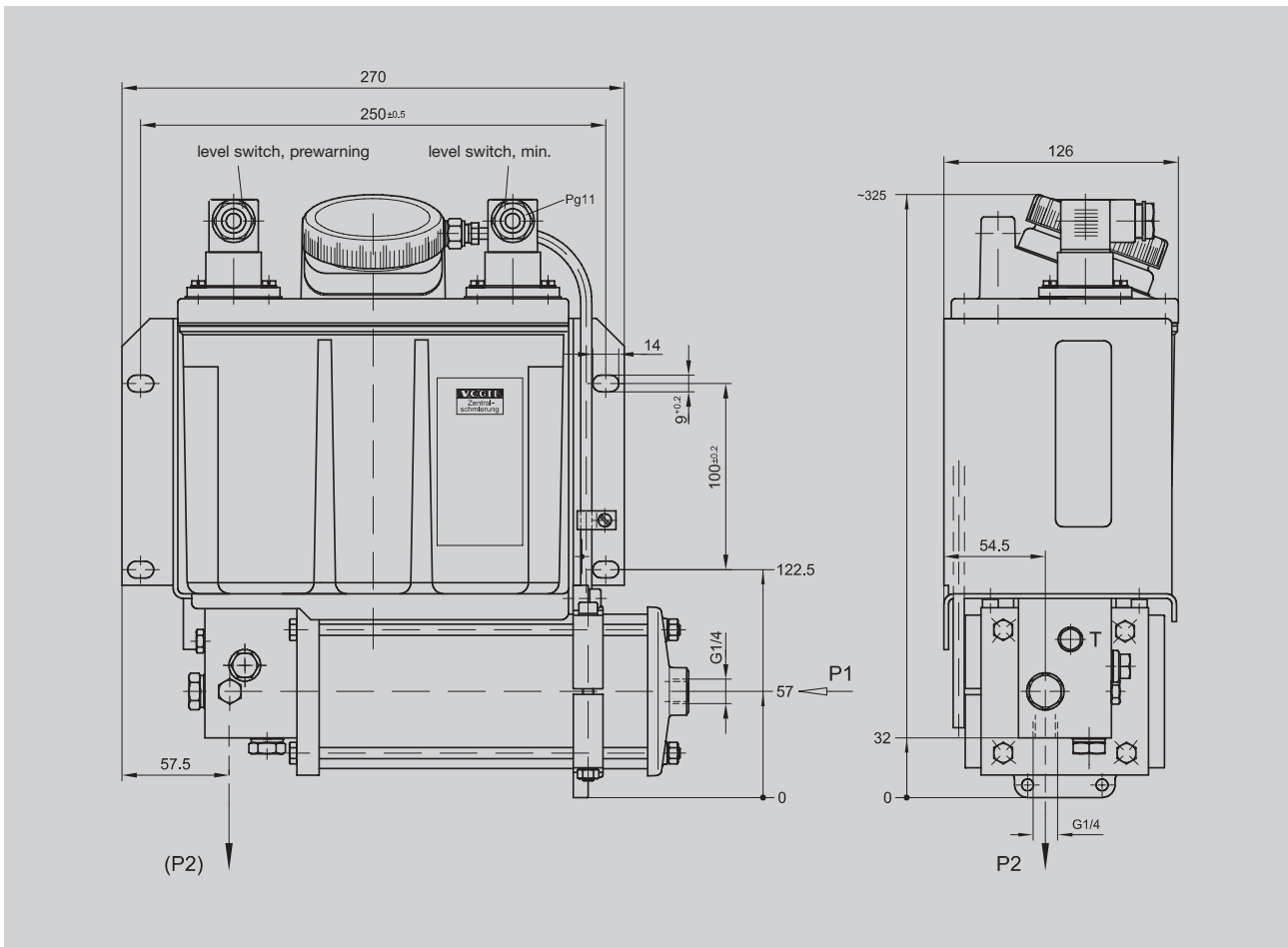

Technical data

Order No.	PEF-99W-S3
Delivery rate per stroke	50 ccm
Max. permissible air pressure P1	10 bars
Reservoir capacity	3 liters
Mounting position	as shown
Lubricant	fluid grease, NLGI grades 000, 00

P1 = pressure port

P2 = pressure port to system

Ports tapped for solderless tube connection.

Gear pump units with automatic relief of pressure in main line

These units are designed for centralized lubrication systems used in conjunction with piston distributors (total-loss lubrication) and are equipped with the **relief and safety valves required for the same**.

The drive is provided by a three-phase motor.

The pumps are located below the grease level, in contrast to oil units.

Intermittent operation is required for the distributors' sequence of operations, i.e. when the pump is running, the distributors are pressurized; when the pump is at rest, the main line is relieved of pressure and the distributors reverse. This work cycle is achieved by timing the electric motor.

For suitable control units see leaflets 1-1700-1-US – 1-1700-4-US

Bestell-Nr.	Delivery-rate [l/min]	Reservoir capacity [l]	Reservoir material *)	Lubricant level monitoring	Special technical feature
MFE2-KW3F-2	0.2	3	K	●	– 24 V lubricant level switch with M12x1 plug connector
MFE2-KW3F-S9	0.2	3	K	●	– 24 V level monitoring with M12x1 plug connector – Motor with Harting connector to DaimlerChrysler specs
MFE2-KW3F-S11 -	0.2	3	K	●	– 24 V level monitoring with M12x1 plug connector – IP55 type of motor enclosure
MFE2-KW3F-S13	0.2	3	K	●	– 24 V level monitoring – Motor UL (appr.)
MFE2-KW6F-S1	0.2	6	K	●	– 2 24 V lubricant level switches for minimum and advance warning
MFE2-KW6F-S5	0.2	6	K	●	– 2 24 V lubricant level switches for minimum and advance warning – Filler coupling to WV AG specs
MFE2-KW6F-S6	0.2	6	K	●	– 2 24 V lubricant level switches for minimum and advance warning – Filler coupling to CNOMO (France) specs
MFE2-KW6F-S7	0.2	6	K	●	– 2 24 V lubricant level switches for min. and max. level
MFE2-KW6F-S13	0.2	6	K	●	– 2 24 V lubricant level switches for minimum and advance warning – Motor UL (appr.)
MFE2-KW6F-S16	0.2	6	K	●	– 2 24 V lubricant level switches for minimum and advance warning with M12x1 plug connector – Filler coupling
MFE2-KW6F-S21	0.2	6	K	●	– 2 24 V lubricant level switches for minimum and advance warning with M12x1 plug connector – Motor with Harting connector to DaimlerChrysler specs
MFE2-BW7F-S3	0.2	6	M	●	– 2 24 V lubricant level switches for minimum and advance warning – Filler coupling to VW AG specs

*) reservoir material: **K = plastic**
M = metal

Technische Daten

Order No. **MFE2-KW3F-2** **MFE2-KW6F-S1**
 Reservoir capacity 3 liters 6 liters

Unit

Flow rate ¹⁾ 0.2 l/min
 Continuous operation atp max 20 bars
 Brief operation atp max 38 bars
 Operating temperature + 10 to +40 °C
 Mounting position as shown
 Lubricant fluid grease, NLGI grades 000, 00
 compatible with plastics, NBR elastomers,
 copper and copper alloys

Motor

Rated power 70 W
 Speed ¹⁾ 2700 rpm
 Type of enclosure to DIN 40050 IP54
 Insulation class F
 Voltage cf. table
 Frequency 50/60 Hz

Level switch

MFE2-KW3F-2 24 V DC
250 mA
 MFE2-KW6F-S1 10 to 55 V DC

Connectable load: brief operation (max. 1s) max. 1 A
 continuous operation max. 350 mA

(Other units on request)

¹⁾ Bei Frequenz 50 Hz

Voltage (please indicate range when ordering)

Range I Δ/Y 100-130 V / 173-225 V, 50 Hz Δ/Y 0.90/0.53 A
 Δ/Y 120-156 V / 208-270 V, 60 Hz
 Range II Δ/Y 207-254 V / 360-440 V, 50 Hz Δ/Y 0.50/0.29 A
 Δ/Y 249-305 V / 432-528 V, 60 Hz
 Range III Δ/Y 230-290 V / 398-500 V, 50 Hz Δ/Y 0.40/0.23 A
 Δ/Y 290-346 V / 500-600 V, 60 Hz

Any voltages deviating from these ranges can only be used for the respectively ordered voltage and frequency.

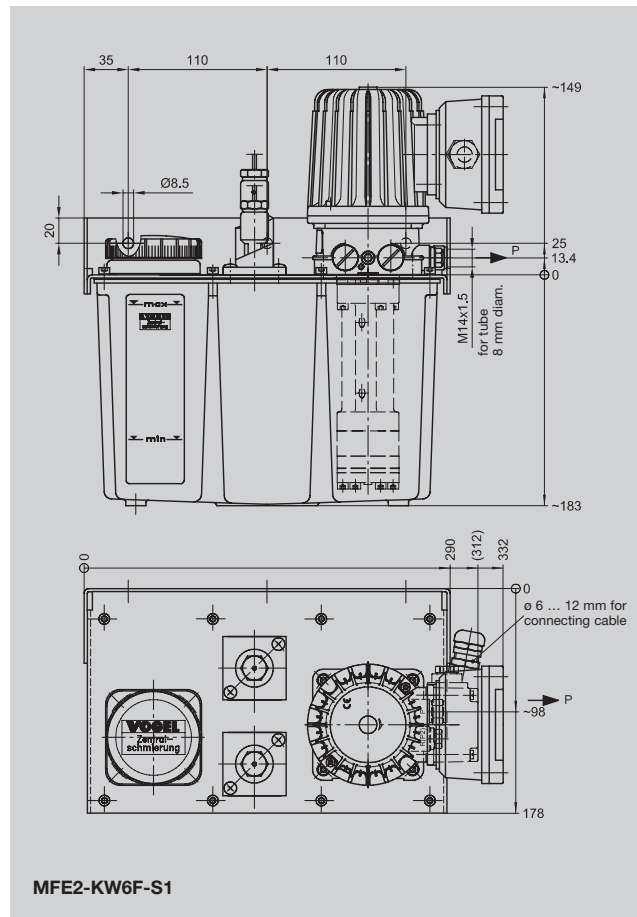
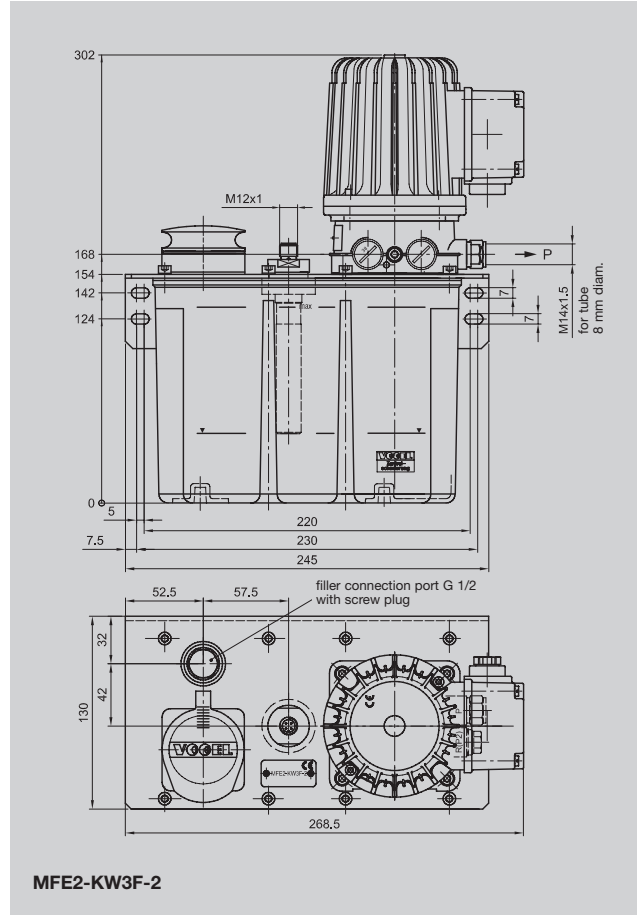

Piston distributors

Piston distributors meter out and distribute the lubricant delivered by an intermittently actuated pump.

The amounts of lubricant for the individual lube points are determined by exchangeable metering nipples. The metered amount is indicated on the individual metering nipples. The amount of lubricant required to meet the respective need can also be regulated by way of the lubrication frequency.

Depending on the amounts required and spatial constraints, it is possible to choose from among four groups of distributors that differ in terms of their metering ranges and sizes.

The functional principle of all the groups is the same, but there are differences in their design.

Different distributor groups can be used in one system.

Remarks:

Seal material: NBR.

In general, the operating conditions prescribed for the respective pump units will apply to operation of the distributors, provided the permissible limit values are observed.

Limit values for the distributors:

Temperature range: 0 °C to +80 °C

Lubricant: fluid grease, NLGI grades 000, 00

Piston distributors, Group 340 0.01-0.1 ccm (for fluid grease, NLGI grades 000, 00)

Notice: Piston distributors comprising Groups 340, 350 and 390 are only supplied complete with metering nipples. Possible tubing connection: M8x1 port tapped for solderless 4 mm diam. tube connection..

See leaflet 1-5015-US for piston distributors with quick connector system.

See leaflet 1-0103-1-US for quick connectors for plastic tubing.

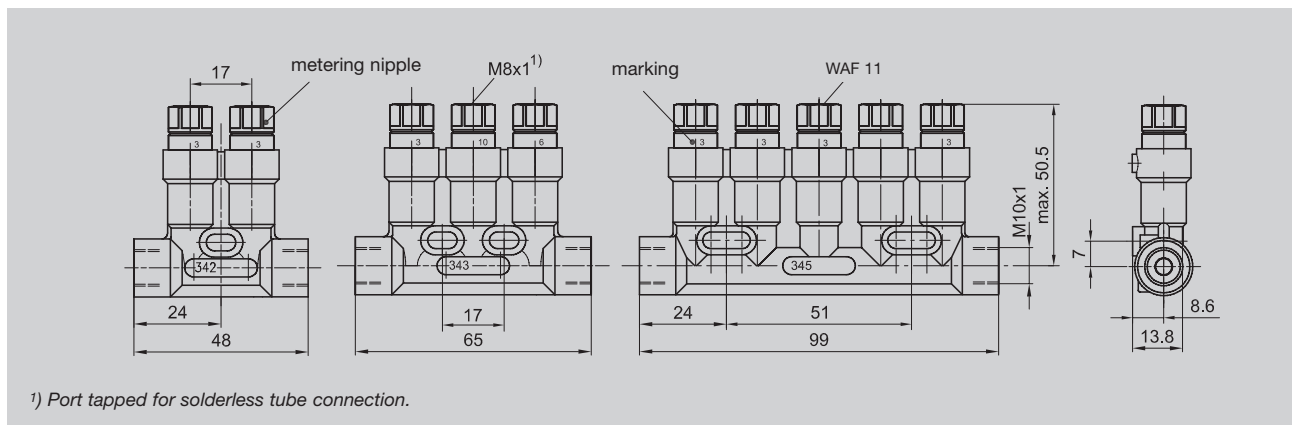

¹) Port tapped for solderless tube connection.

Piston distributors

(only available with metering units installed)

Order No.	Number of lube points
342-5.-000	2
343-5.-.00	3
345-5.-...	5

Metering nipple with O-ring, exchangeable

Rated metered quantity [cm³]	Order key	Marking on metering nipple	Order No.
0.01	1	1	Metering nipple not exchangeable
0.03	2	3	341-853-K
0.06	3	6	341-856-K
0.1	4	10	341-860-K

A minimum pressure of **12 bars** is required in the main line for the distributor to function.

To order

The order No. has 9 places.

The **order key** is used to supplement the order No. in compliance with the desired metering rates.

Order example: Piston distributor, 3-port type, 343-5.-.-...

metered with (from left to right) 0.03 – 0.1 – 0.06 ccm

Order key: 2 4 3

Order No.: 343-524-300

Distributor comprising Group **340-...** are designed for **direct connection** to a main tubing line with a 6 mm diameter (double tapered ring and socket union).

Piston distributors, Group 350 0.1-0.3 ccm (for fluid grease, NLGI grades 000, 00)

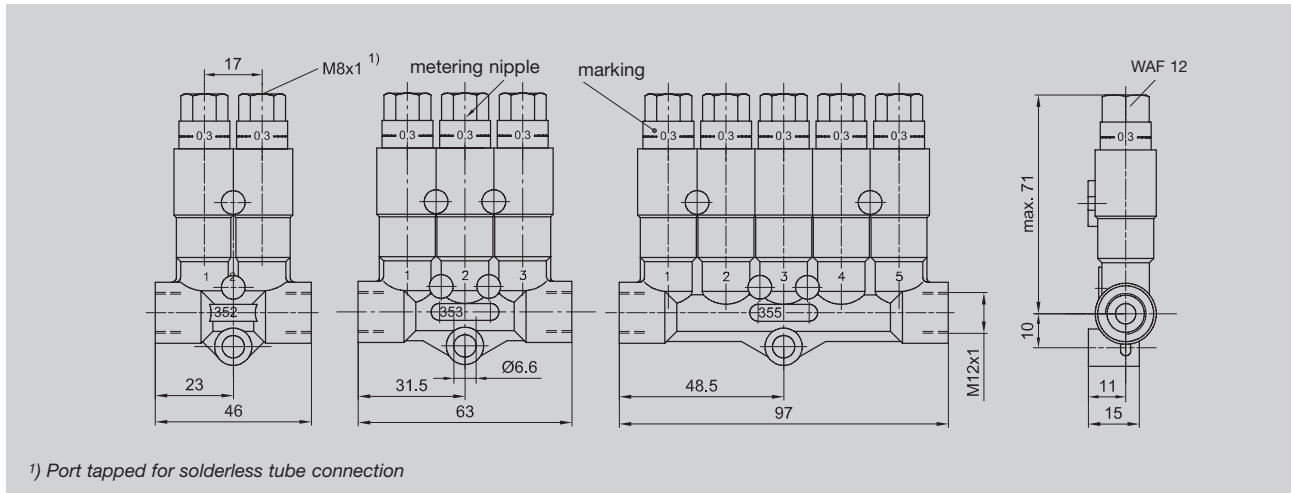

Piston distributors
(only available with metering units installed)

Order No.	Number of lube points
352-1..-000	2
353-1..-.00	3
355-1..-..	5

Metering nipple with O-ring, exchangeable

Rated metered quantity [ccm]	Order key	Marking on metering nipple	Order No.
0.1	4	0,1 1 ring	995-993-610
0.2	5	0,2 2 ring	995-993-620
0.3	6	0,3 1 ring dashed	995-993-630

A minimum pressure of **12 bars** is required in the main line for the distributor to function.

See page 9 for order example.

Piston distributors, Group 390 0.1-0.3 ccm (for fluid grease, NLGI grades 000, 00)

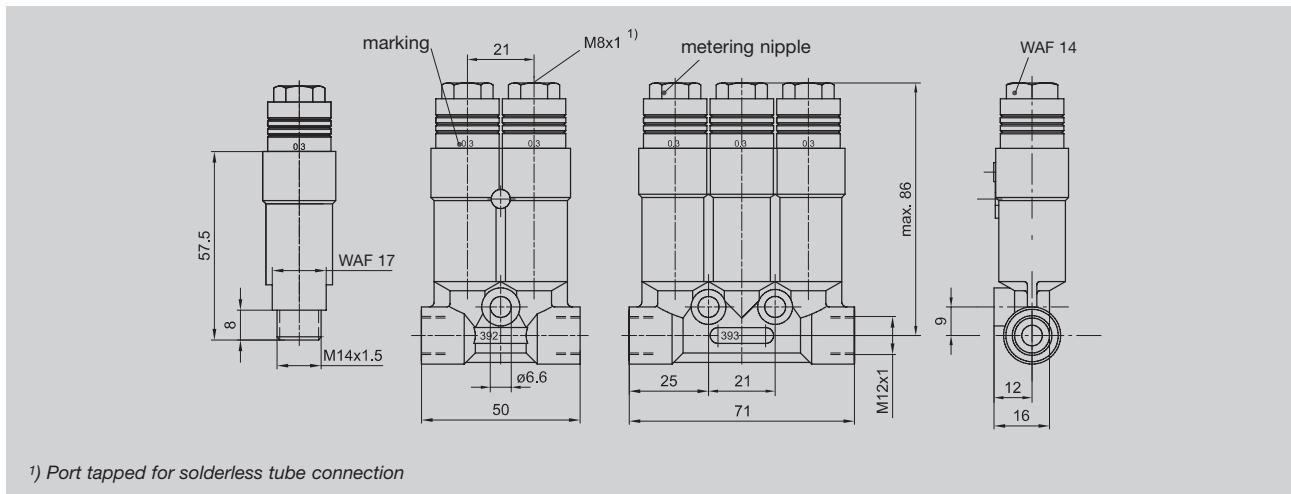

Piston distributors
(only available with metering units installed)

Order No.	Number of lube points
391-1.0-000	1
392-1..-000	2
393-1..-.00	3

Metering nipple with O-ring, exchangeable

Rated metered quantity [ccm]	Order key	Marking on metering nipple	Order No.
0.1	4	0.1 1 ring	391-010-K-S1
0.2	5	0.2 2 ring	391-020-K-S1
0.3	6	0.3 3 ring	391-030-K-S1

A minimum pressure of **26 bars** is required in the main line for the distributor to function.

See page 9 for order example.

Metering units for direct connection to lube points

These metering units are designed for direct connection to the lube points.

In main lines (connection: pump – system distributor) it is possible to check the pressure build-up and – if necessary – the pressure reduction with the help of pressure switches.

In the secondary lines (connection: distributor – lube point) the pump pressure is no longer a direct factor. If secondary lines are to be monitored, they must first be turned into main lines, which can be done by screwing **type G, T, W** metering units directly into the lube-point threads.

The metering units are prefitted with union nuts or socket unions and (single) tapered rings so it's easy to install the tubing (plastic, steel and metal tubing):

- Introduce the tubing all the way to the stop (Type **G** and **W** about 12 mm; type **T** about 20 mm).
- Tighten union nut or socket union.

All three types are supplied complete with tapered ring and union (nut).

Type

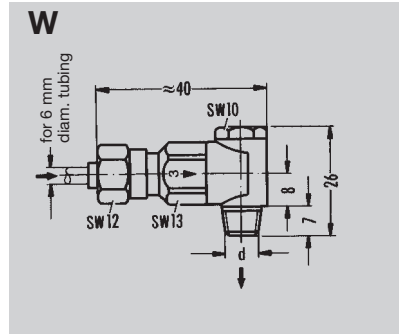
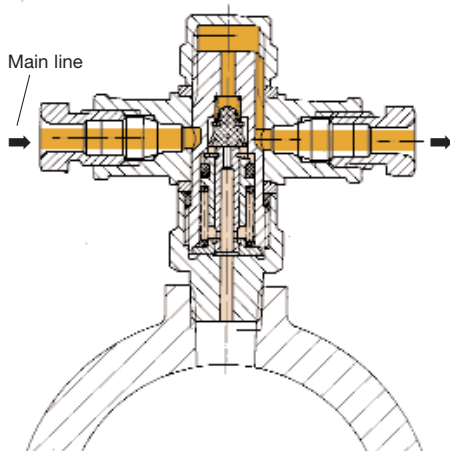
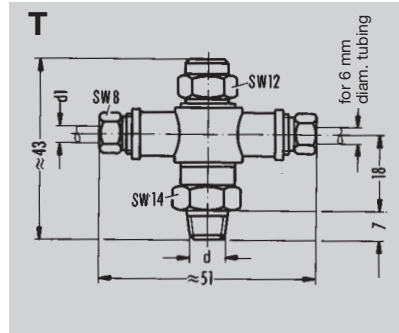
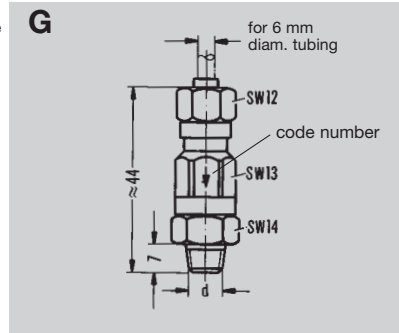

Metered quantity [ccm]	Code No.	Screwed stud end d	Order No.		
			Type G	Type T	Type W
0.03	3	M 8 x 1 tap.	321-603G1		321-603W1
		M10 x 1 tap.	321-603G2		321-603W2
		R 1/8 tap.	321-603G3		321-603W3
0.06	6	M 8 x 1 tap.	321-606G1		321-606W1
		M10 x 1 tap.	321-606G2		321-606W2
		R 1/8 tap.	321-606G3	321-606T3	321-606W3
0.1	10	M 8 x 1 tap.	321-610G1		321-610W1
		M10 x 1 tap.	321-610G2		321-610W2
		R 1/8 tap.	321-610G3	321-610T3	321-610W3



A brand of the SKF Group

Willy Vogel AG

Motzener Strasse 35/37
12277 Berlin, Germany
P.O. Box 970444 · 12704 Berlin

Tel. +49 (0) 30 72002-0
Fax +49 (0) 30 72002-111
info@vogel-berlin.de
www.vogelag.com

Willy Vogel AG

2. Industriestrasse 4
68766 Hockenheim
Germany

Tel. +49 (0) 6205 27-0
Fax +49 (0) 6205 27-132
info@vogel-berlin.de
www.vogelag.com

Vogel France SAS

Rue Robert Amy, B.P. 70130
49404 Saumur cedex
France

Tel. +33 (0) 241 404 200
Fax +33 (0) 241 404 242
info@vogelfrance.com
www.vogelfrance.com

Notice!

All products from VOGEL may be used only for their intended purpose. If operating instructions are supplied together with the products, the provisions and information therein of specific relevance to the equipment must be observed as well.

In particular, we call your attention to the fact that hazardous materials of any kind, especially the materials classified as hazardous by EC Directive 67/548/EEC, Article 2, Par. 2, may only be filled into VOGEL centralized lubrication systems and components and delivered and/or distributed with the same after consultation with and written approval from VOGEL.

All products manufactured by VOGEL are not approved for use in conjunction with gases, liquefied gases, pressurized gases in solution and fluids with a vapor pressure exceeding normal atmospheric pressure (1013 mbars) by more than 0.5 bar at their maximum permissible temperature.